

Water Supply Assessment for Little Tallapoosa River Dam No. 20 Carroll County, Georgia



Prepared for:
**Georgia State Soil and Water Conservation
Commission**

Prepared by:
**Schnabel Engineering
Jordan Jones and Goulding**

December 21, 2007



EXECUTIVE SUMMARY

The Georgia Soil and Water Conservation Commission (GSWCC), in partnership with the Natural Resources Conservation Service (NRCS) and the Georgia Environmental Protection Division (EPD) initiated a study to evaluate whether or not any of the existing watershed dams, designed and constructed under federal laws PL 544 and PL 566, could be modified to serve as water supply reservoirs. The evaluation process went through several iterations, the most recent of which can be found in the Finding Report dated December, 2007 on file with the GSWCC. The Finding Report identified 20 structures that had sufficient potential for relatively high yields with relatively small environmental and infrastructural impacts, when compared to the other projects evaluated. The selected twenty dams were further evaluated to identify project parameters.

The following report summarizes the evaluation of the Little Tallapoosa River Structure Number 20, which is located in Carroll County, Georgia. For the purposes of this report, the existing normal pool will be raised to impound a water supply pool having a surface area of approximately 93 acres.

For convenience, the following summary lists the major findings of this evaluation. This summary should not be utilized as a separate document or in lieu of reading the entire report, including the Appendix.

- Approximately 279 acres of land will be impacted by the proposed reservoir and dam raising
- Approximately 15 structures will be impacted by the proposed reservoir and dam raising
- Three county roads will be impacted.
- For the modeled conditions, the drought of record in the Little Tallapoosa 20 Basin is the period 1999-2002. For a water supply storage of approximately 290 million gallons and supplementation of natural reservoir inflow by pumped diversions (maximum 2 million gallons per day, mgd) from nearby Little Tallapoosa River, the safe yield of the reservoir is estimated to be 0.87 mgd.
- Approximately 102 acres of palustrine wetlands will be impacted by the proposed reservoir and dam raising
- Approximately 37 acres of lacustrine/palustrine open waters will be impacted by the proposed reservoir and dam raising
- Approximately 11,570 linear feet of lower perennial streams will be impacted by the proposed reservoir and dam raising
- Approximately 8,510 linear feet of intermittent streams will be impacted by the proposed reservoir and dam raising
- Review of existing cultural resources information indicated one identified cultural resource site within the maximum reservoir pool limits of Little Tallapoosa River 20.
- Review of available information did not indicate any primary or secondary trout streams, or 303(d) / 305(b) listed streams occurring within the maximum reservoir pool limits of Little Tallapoosa River 20.
- Project cost is estimated in 2007 dollars at \$71,000,000.

PREFACE

The results of the analyses presented herein are based upon United States Geological Survey (USGS) quadrangle maps and, therefore, should be utilized for planning purposes only. If the subject project is identified as having a possibility of progressing past this analysis, additional studies will be required. These studies will include but not be limited to detailed environmental evaluations, detailed yield analyses, preliminary engineering design, and detailed cost estimating. These additional studies will be required prior to beginning detailed design work and/or land acquisition. The level of study presented herein shall be considered as a screening tool to evaluate the proposed project relative to other projects. Until further studies are performed, actual yield and costs associated with the entire project cannot be readily determined.

TABLE OF CONTENTS

EXECUTIVE SUMMARY	
PREFACE	
INTRODUCTION	1
BACKGROUND	1
ENGINEERING FACTORS	6
SAFE YIELD ANALYSIS	9
RESULTS	13
ENVIRONMENTAL CONSIDERATIONS	15
PROJECT CONSTRUCTION COST ESTIMATE NARRATIVE.....	22
APPENDIX.....	30

INTRODUCTION

The project team of Schnabel Engineering South, LLC (Schnabel), Jordan Jones and Golding (JJ&G), Joe Tanner and Associates, and the Law Office of William Thomas Craig were retained by the Georgia State Investment and Financing Commission as the agent for the Georgia Soil and Water Conservation Commission to evaluate 166 existing flood control structures. The subject structures were originally designed and constructed under Federal laws PL 544 and PL 566 to control storm water runoff (flooding) and collect sediment. The goal of this evaluation was to identify impoundments that could be enlarged to provide a relatively reliable water supply. The results of the evaluation were utilized to select twenty of the dams and reservoirs that had potential for relatively high yields with relatively small environmental and infrastructural impacts, when compared to the other projects evaluated. The selected twenty dams were further evaluated to identify project parameters. The additional evaluation included the following:

- More detailed yield analyses
- More detailed environmental evaluation
- Cost estimation of proposed modifications

The Little Tallapoosa Watershed Dam Number 20 in Carroll County, Georgia was one of the structures selected for further evaluation.

BACKGROUND

The subject dam, Little Tallapoosa River Watershed Dam Number 20 (Little Tallapoosa Dam No. 20), is located approximately 4-½ miles northeast of Carrollton, Georgia in Carroll County. More specifically, the dam is located on Hendricks Creek just upstream of Shady Grove Road.

The existing dam was designed in 1960 and constructed in 1960. As designed, the dam had a crest elevation of 1025.5 feet and impounded a reservoir that had a surface area of approximately 57 acres at a normal pool elevation of 1009.5 feet. The crest of the emergency spillway was designed to be at elevation 1022.4 feet. Figure 1 shows the location of the subject dam within the county as well as a plan view of the existing embankment and emergency spillway. According to the Soil Conservation Service (SCS), now known as the Natural Resources Conservation Service (NRCS), Dam Inventory sheet, the dam was originally designed and constructed as a Class 'A' or low-hazard dam. The state Safe Dams program classifies the existing dam as a Category 2 structure. When designed, the emergency spillway (now referred to as an auxiliary spillway) had a four percent chance of operating in any given year. This results in the auxiliary spillway operating during storm events equal to and greater than the 25-year event. With the exception of engineering, land acquisition, and project administration, the dam was completed for a cost of approximately \$23,000.

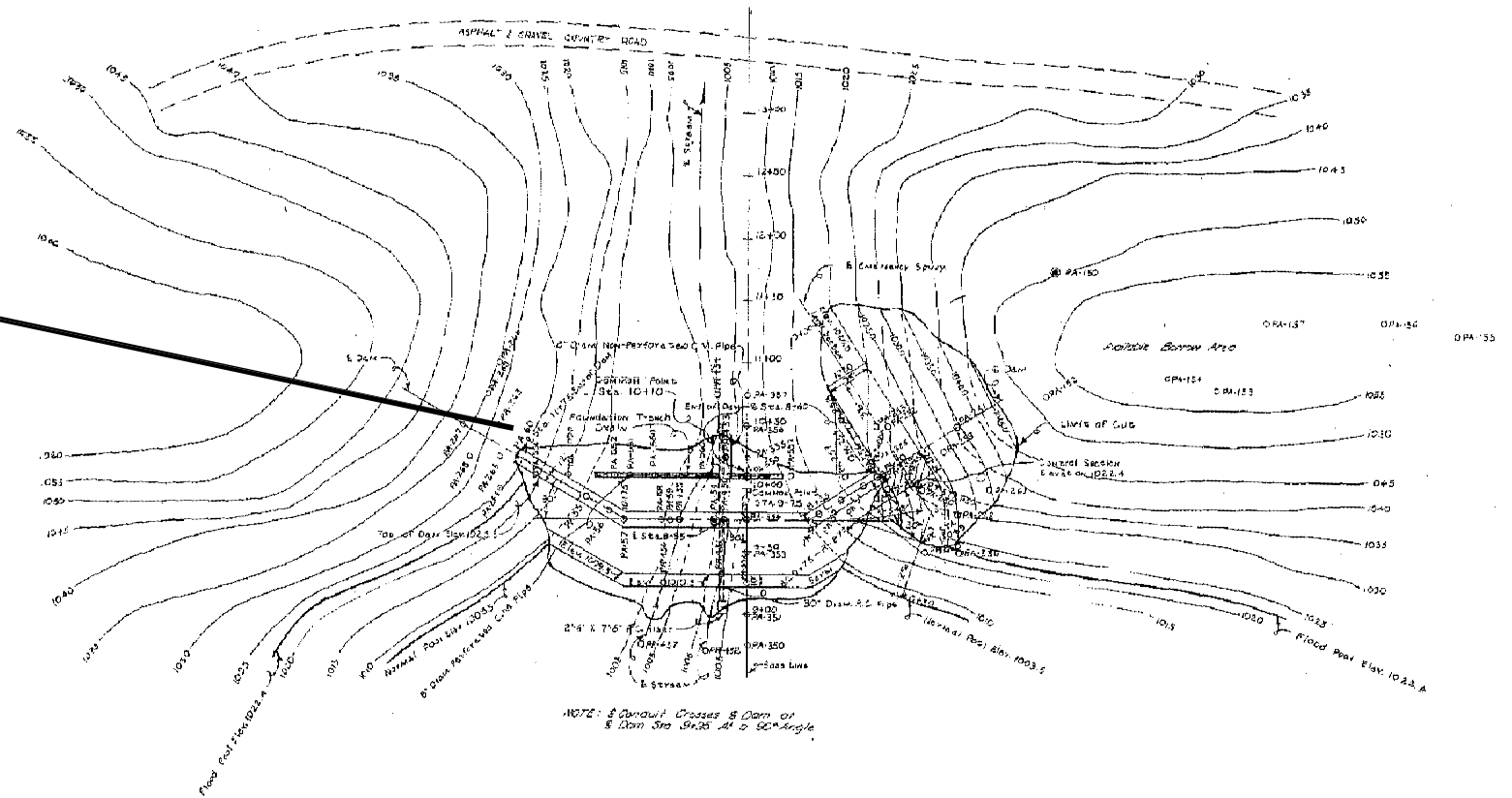
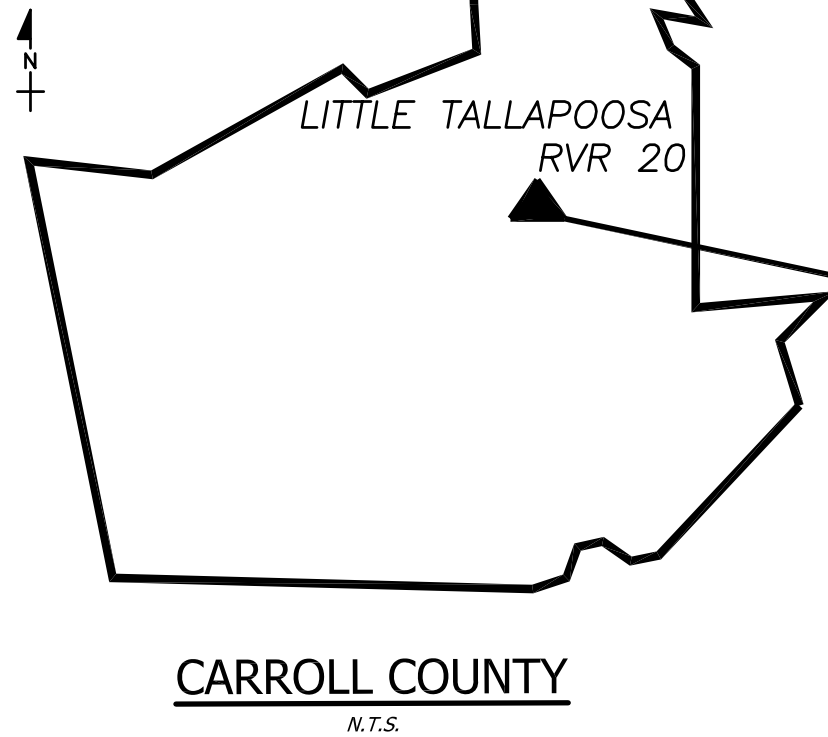

EXISTING SITE PLAN

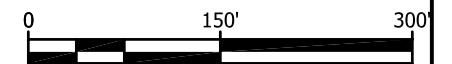

© Schnabel Engineering 2007 All Rights Reserved



NRCS WATERSHED DAM ASSESSMENT
LITTLE TALLAPOOSA RIVER NO. 20

SITE LOCATION MAP
PROJECT NO. 07170030.01
FIGURE 1

Needs and Demand Evaluation

Population projections through the year 2025 were obtained from the Carroll County Comprehensive Plan (adopted in December, 2004). Projections to 2057 were extrapolated based on the assumption of the same constant growth rate that was shown in the Comprehensive Plan. These projections can be seen in Table 1.

Table 1
Population Projection

Year	Population Projection
2000	87,268
2005	101,844
2010	114,551
2015	128,844
2020	144,920
2025	163,002
2030*	183,340
2035*	206,216
2040*	231,946
2045*	260,886
2050*	293,438
2055*	330,051
2057*	346,524

Data Source: from Planning Works, LLC in Carroll County Comprehensive Plan

**Population Calculated based on yearly % growth from 2005-2025*

Water demand projections were calculated based on population projections and water withdrawal data for Carroll County in 2000. According to the US Census, the population of Carroll County was 87,268 in 2000, while the water withdrawal was 11 million gallons per day (MGD) based on the document “Water Use in Georgia by County for 2000”, (Information Circular 106, Julia Fanning, USGS, Atlanta, 2003). The Carroll County Water Authority currently holds a surface water withdrawal permit from the HC Seaton Reservoir for 8.0 MGD. Municipalities within the county also hold the following surface water withdrawal permits: the City of Carrollton (12 MGD from the Little Tallapoosa River), the City of Villa Rica (1.5 MGD from Lake Paradise and Cowens Lake), and the City of Bowden (1.0 MGD from Lake Tysinger, and 0.36 MGD from Indian Creek). In addition to the surface water permits, the Carroll County Water Authority and the City of Villa Rica hold groundwater withdrawal permits for 0.75 MGD and 0.125 MGD respectively. All totaled, water withdrawal permitted for public use in Carroll County is 23.7 MGD (all numbers are reported in permitted monthly average).

The overall usage was calculated to be 130 gallons per day (gpd) per person. This number was used as a constant through 2057 to create water withdrawal projections. The water withdrawal projection for 2057 was calculated to be approximately 45 MGD. This figure includes all unaccounted for water (UAW), and the assumption that industrial usage would increase with the increase in Carroll County population. Water withdrawal projections are shown in Table 2.

Table 2
Water Withdrawal Projection

Year	Water Withdrawal Projection (MGD)
2000	11
2005	13
2010	15
2015	17
2020	19
2025	21
2030	24
2035	27
2040	30
2045	34
2050	38
2055	43
2057	45

Proximity to Surface Water Intakes

Based on the GIS database developed for this project, the closest surface water intake structure is downstream of the dam on the Little Tallapoosa River. This structure is operated by the City of Carrollton. The stream distance to the intake is approximately 5.1 miles. The following figure illustrates the location of the nearest surface water intake location to Little Tallapoosa River 20.

Figure 2
Distance to Nearest Intake

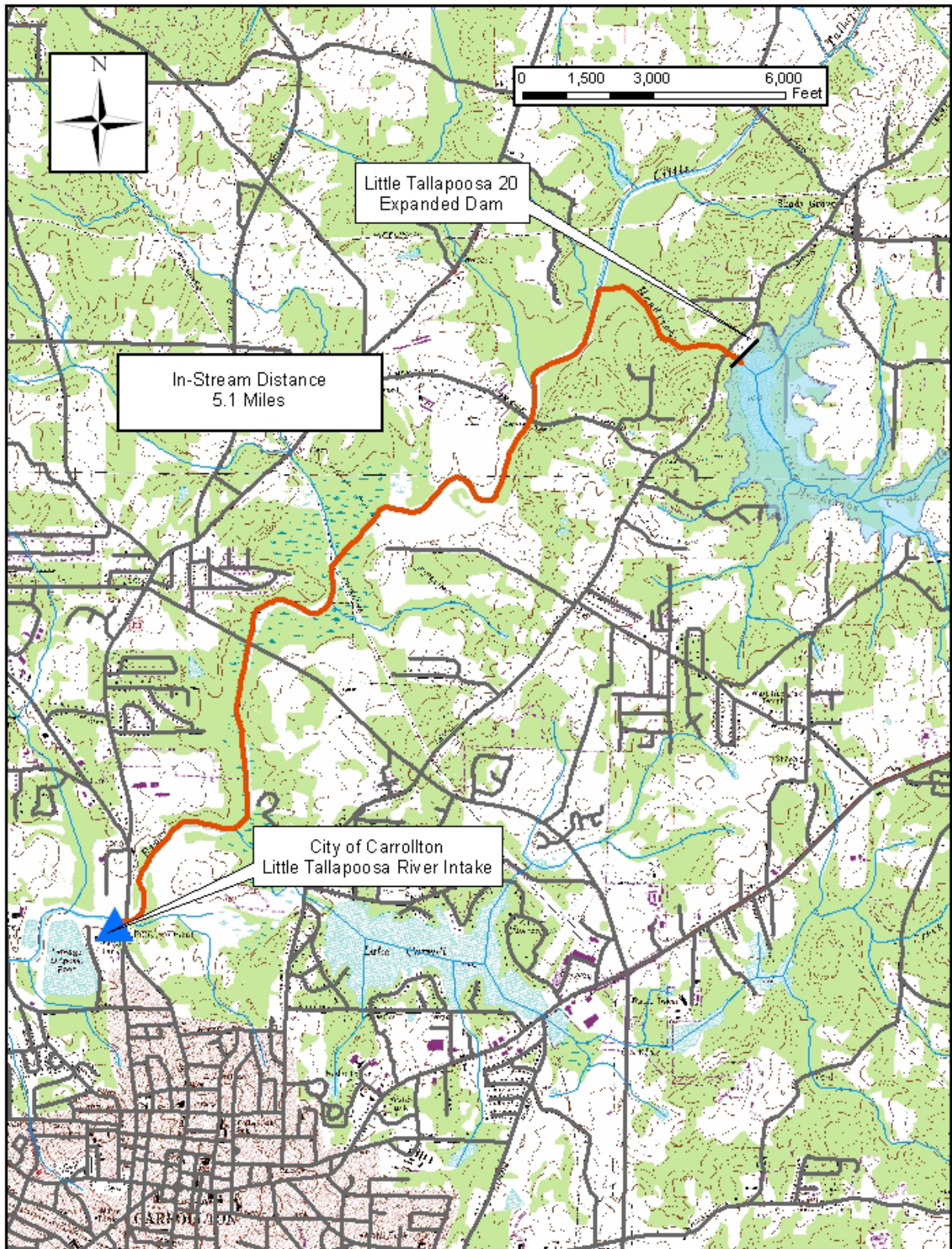

ENGINEERING FACTORS

Proposed Dam

The proposed dam, which will incorporate the existing dam, will have a crest elevation of 1040 feet, an auxiliary spillway elevation of 1030 feet, and a water supply pool elevation of 1021 feet. The proposed dam will impound a reservoir that has a surface area of approximately 93 acres and storage volume of approximately 290 million gallons (MG) at the water supply pool elevation. A plan view of the proposed reservoir is shown in Figure 3.

Several engineering assumptions were made pertaining to spillway configuration. The spillway system for the proposed dam was assumed to consist of a principal spillway in the form of a 2'-6" by 7'-6" interior dimension reinforced concrete riser with a 30-inch diameter reinforced concrete low-level outlet pipe and an auxiliary spillway in the form of a 250-foot wide reinforced concrete chute spillway with ogee crest. The intent of the proposed principal spillway is to approximate the flows that are being discharged by the current spillway system during the two through 100-year storm events. The size of the auxiliary spillway was approximated by estimating the peak inflow that would occur during the Probable Maximum Precipitation (PMP) event and computing the spillway width that would be required to pass the estimated inflow with a given amount of hydraulic head. The available hydraulic head was determined by comparing the drainage basin area to lake surface area. The structures that had a drainage basin area to lake surface area ratio equal to or in excess of ten were allotted 15 feet of hydraulic head to pass the PMP inflows, while the structures that had a ratio of less than ten were allotted ten feet of hydraulic head to pass the PMP inflows. The assumption that the dam would be required to pass the inflow resulting from the PMP storm event is based on the history of the Georgia Department of Natural Resources Environmental Protection Division Safe Dams Program (Safe Dams) reviewing plans for water supply reservoir dams regardless of classification. As such, the dam would generally be required to comply with the engineering guidelines established by Safe Dams. The proposed dam would have a relatively high likelihood of being classified as high-hazard or Class 'C' by the NRCS, as well as Safe Dams. For this reason, it has been assumed that the dam will be required to pass the full PMP storm event.

The proposed dam and flood pool will:

- Impact 15 structures
- Require the purchase of 276 acres from 120 parcels
- Require the purchase of 3 acres of easement area for state required buffer
- Impact three local/county roads

Figure 4 displays the proposed reservoir area as well as the buffer and affected parcels. The 15 affected structures were identified from aerial photographs. The types of structures were not identified on the ground and could be houses, barns, trailers, etc. A more detailed ground survey will be required to determine the type of each structure and the corresponding purchase price of each structure.

Figure 3
Proposed Reservoir Area Map

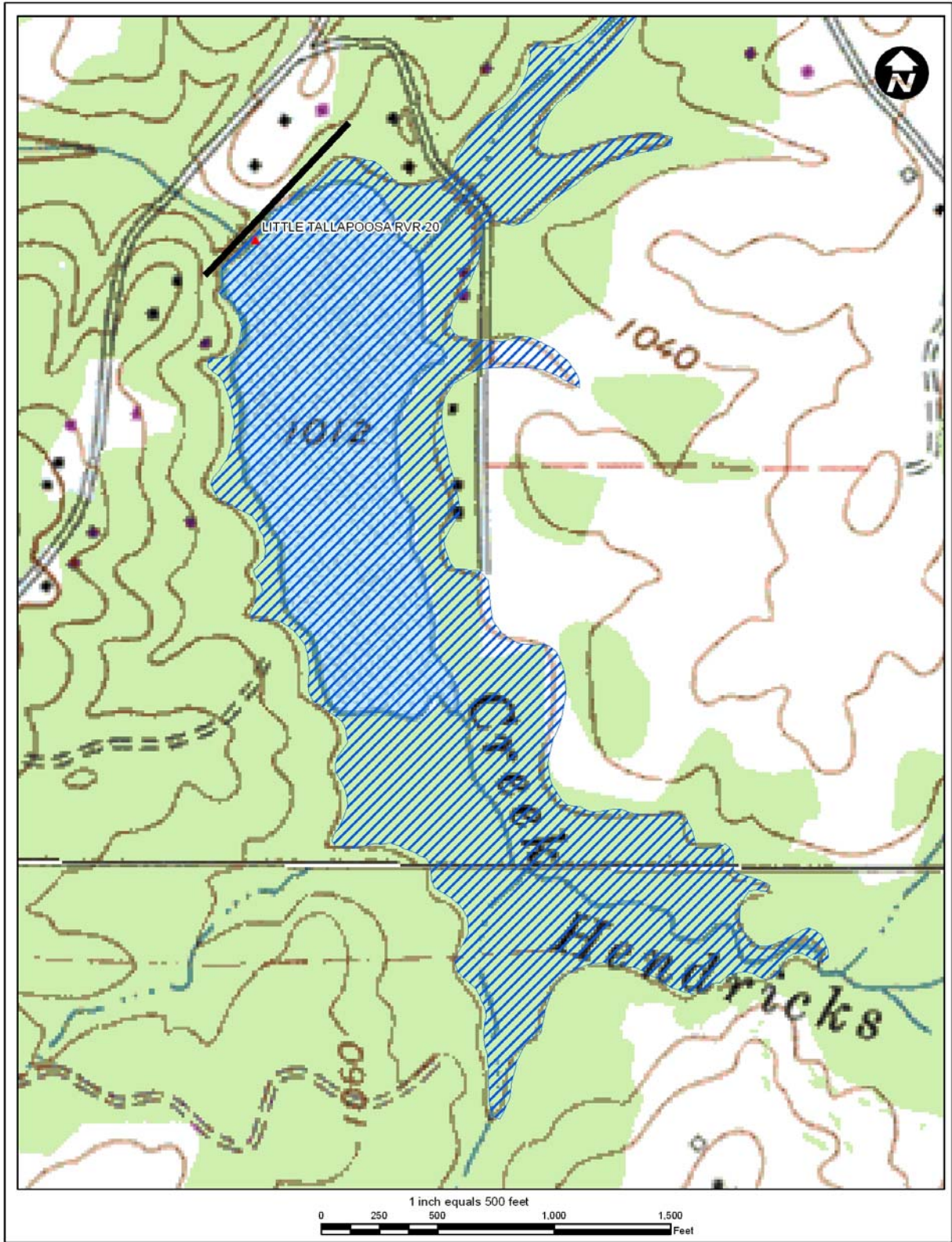
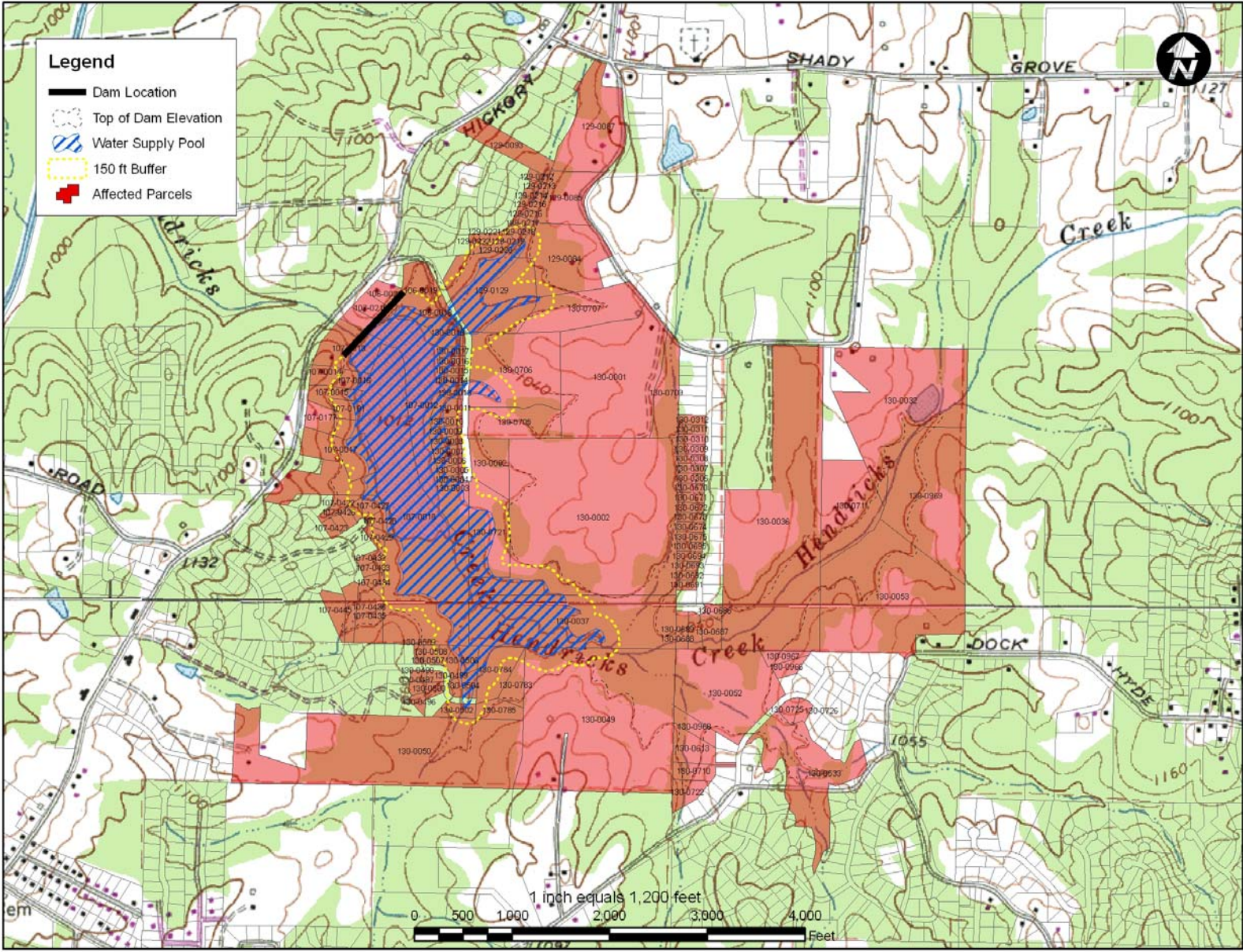

Figure 4
Land Acquisition and Buffer Areas



SAFE YIELD ANALYSIS

Definition

Reservoir safe yield is generally defined as the reliable withdrawal rate of water with acceptable quality that can be provided by reservoir storage through the critical drought period. The critical drought period in the State of Georgia is defined as the drought of record and in any given drainage basin can vary depending on reservoir size and other factors. This study was based on the critical drought period from 1999-2002; however, the current drought could possibly exceed the existing drought of record. If this were to occur, the computed yields detailed herein would be reduced. Safe yield in this study was simulated using a constant average annual demand. The justification for this is that while total water demands after declaration of a drought condition are usually less than normal, this situation is typically offset by higher than average demands prior to declaration of the drought condition. Safe yield is dependent upon the storage and hydrologic (rainfall/runoff/evaporation) characteristics of the source and source facilities, the selected critical drought, upstream and downstream permitted withdrawals, and the minimum in-stream flow requirements.

The proposed reservoir is a “pumped-storage” reservoir, where natural inflow into the reservoir is supplemented with pumped diversions from a nearby larger stream or river. Water is pumped from a larger river when runoff is plentiful, and is stored in the reservoir for times of drought. Pumped diversions increase safe yield, and generally result in fewer environmental impacts compared with reservoirs on main-stem rivers.

Analysis Method

The Little Tallapoosa River below Bowden gage (USGS 02413210) was selected for use in this analysis; however, its record period only extends from December 1999 to September 2004. Therefore, a correlation of the Bowden gage with the Tallapoosa River Near Heflin, AL gage (USGS 02412000) was performed, and regression-based adjustment was applied to the Heflin gage flows (Figure A-1, Appendix) to lengthen the simulation period. The adjusted flows from the Heflin, AL gage were then used to simulate streamflows in the Little Tallapoosa River and Hendricks Creek. The record period for the Heflin gage (adjusted) extends from July 1952 to present and includes three major droughts (1954-57, 1986-88, 1999-2002), plus the current drought. The diversion pump station was assumed to be located just upstream of the confluence of Hendricks Creek with the Little Tallapoosa River. The straight line pipe distance between the dam and diversion location was estimated at 0.7 mile. The following drainage areas were used in the analysis:

- Dam Site (Hendricks Creek): 5.18 mi²
- Diversion (Little Tallapoosa River): 67 mi²

The pumped diversion location and watershed is shown in Figure 5. The maximum estimated pool level at top of dam was selected during the initial screening phase based on USGS topographic mapping. From that level, a freeboard allowance of 10 feet between the top of dam and the auxiliary spillway was incorporated to pass the spillway

Figure 5
Watershed Location Map

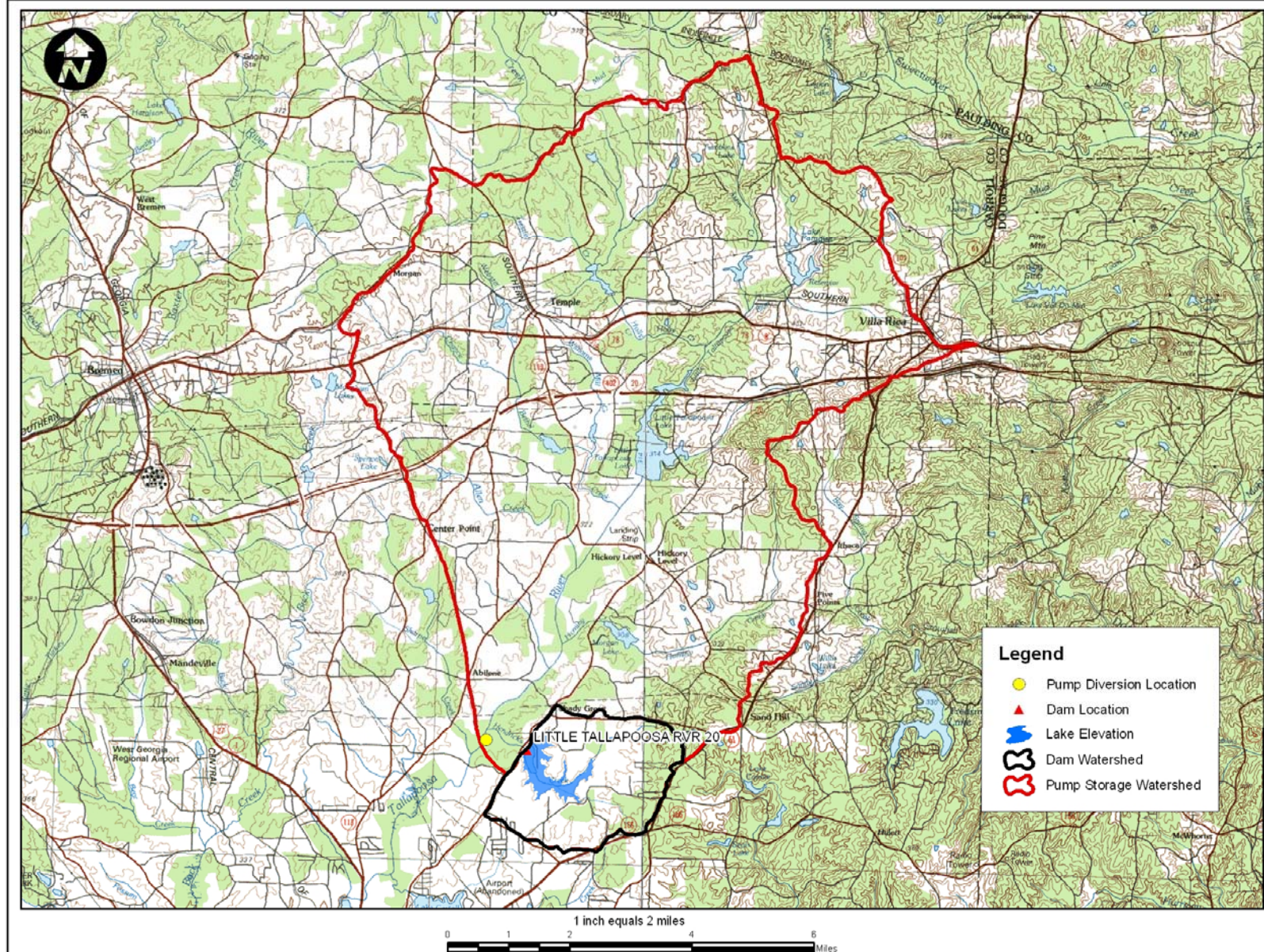

design flood (assumed to be the probable maximum flood). Additional depth to maintain existing flood storage volume (1320 Ac-ft, or 430 MG) was subtracted from the auxiliary spillway elevation to compute the water supply pool elevation used in the analysis of safe yield. Note that more detailed topographic mapping would be needed to more closely approximate the safe yield of the proposed reservoir. Table 3 summarizes the various reservoir elevations and approximate storage volumes. Calculation of stage-area and stage-storage curves is presented as Figure A-2 in the Appendix. Figure 6 below is the stage-storage curve for the reservoir.

Table 3
Summary of Reservoir Data

Stage	Elevation	Volume (Million Gallons)
Maximum Pool (Top of Dam)	1040	1,450
Flood Pool (Auxiliary Spillway Crest)	1030	720
Water Supply Pool	1021	290

Figure 6
Stage-Storage Curve

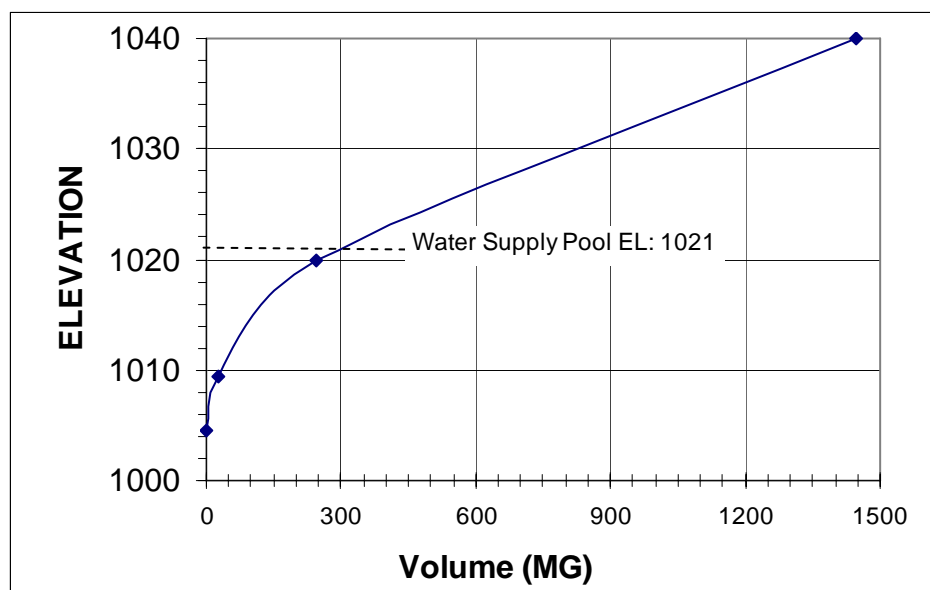

A reservoir operations model was developed to incorporate daily gage data from the selected USGS gage and reservoir shape parameters for estimation of evaporation. The following assumptions were incorporated into the analysis for the estimation of safe yield:

Assumptions:

1. Dead storage of 20% of gross reservoir storage was incorporated to allow for sediment storage and poor water quality in lower reservoir strata.
2. Usable water supply storage was assumed to be the water supply pool storage (calculated as noted above) less dead storage.
3. Pump station diversions were assumed to be from Little Tallapoosa River at the location previously described. Diversions were assumed to occur whenever the reservoir level fell below full water supply pool. Pumped diversions were assumed to be bounded by pumping capacity and by flow restrictions on Little Tallapoosa River (noted below).
4. A minimum in-stream flow (MIF) of 30% AAF at the diversion pump station (Little Tallapoosa River) was used.
5. Allowance for downstream withdrawals by the City of Carrollton would reduce available flow in the stream. In addition to the MIF, the model provided for a prorated let-by for a withdrawal with the following characteristics:

Downstream Withdrawal:	12 mgd
Drainage Area:	96.6 mi ²
Prorated Let-by:	8.32 mgd
6. Upstream withdrawals from Little Tallapoosa River by the City of Villa Rica would reduce available flow in the stream. The model incorporated the upstream withdrawal with the following characteristics:

Upstream Withdrawal:	1.5 mgd
Drainage Area:	3.1 mi ²
MIF	none
7. For the dam site, minimum in-stream flow of 30/60/40 percent average annual flow (AAF) was used. This MIF applies as follows: 30% AAF for July through November; 60% AAF for January through April; and 40% AAF for May, June and December.
8. Return flow from wastewater discharges or septic systems was not considered in the analysis.
9. Evaporation loss was based upon net historical evaporation rates (maximum average day) for each month as recorded at Allatoona Dam (Station No. 181) in Bartow County. Lake evaporation was assumed to be equal to 70% of pan evaporation during each month. Surface area was approximated by a regression equation relating storage to surface area (Figure A-3, Appendix).
10. Streamflow data from the USGS gage was applied in direct proportion of drainage areas to simulate flow into the reservoir and at the diversion location.
11. Total seepage losses would be less than the MIF requirements and, therefore, did not need to be separately considered.
12. Safe yield is that quantity of water that can be provided to meet water demands during the critical drought period.

The attainable safe yield during the analyzed period was found by iteration of the daily mass balance equation:

$$\text{Ending Storage} = (\text{Beginning Storage}) + (\text{Natural Inflow}) + (\text{Pumped Inflow}) - (\text{Water Supply}) - (\text{Evaporation}) - (\text{MIF})$$

The trial safe yield value was varied until the reservoir level just reached the dead storage value, and recovery of the reservoir was computed.

RESULTS

Incorporating the above assumptions, the estimated safe yield of the site was computed. The results of the safe yield analysis are presented in Table 4 and Figure 7. It should be noted that these estimated safe yield values are based on USGS topographic mapping. The estimates could vary significantly based on more detailed mapping, which would be required as part of a final safe yield analysis. The table below presents the estimated safe yield and refill time for a range of pump capacities. We have assumed a refill time of 0.8 years is the maximum refill duration for selection of pump capacity (PC).

Table 4
Safe Yield Summary

Pump Capacity (MGD)	Estimated Safe Yield (mgd)	Refill Time* (years)
0	0.57	1.5
0.5	0.69	1.1
1	0.78	1.1
2	0.87	0.8
3	0.89	0.8

*Refill time is the time from start of drawdown until complete refill to water supply pool

Figure 7
Estimated Safe Yield vs Pump Capacity

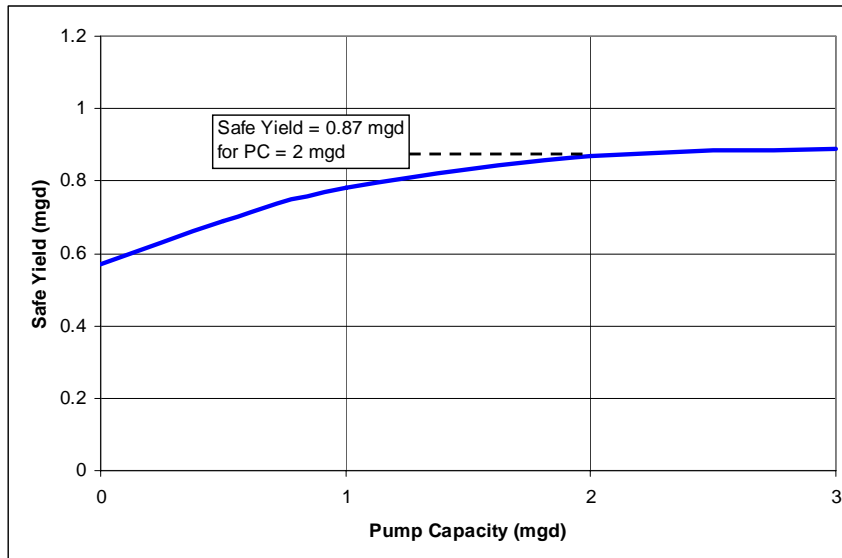

As presented in Figure 7, there is diminishing return (safe yield) with increasing pump capacity (reflecting pump station and pipeline cost). For the purposes of this analysis, an estimated economical safe yield & pump capacity combination were selected from

the above graph. The estimated safe yield for this project is approximately 0.87 mgd for a pump capacity of 2 mgd. These values were used to size and cost out the diversion facilities detailed later in this report. The variation of reservoir elevation over time for the above assumed safe yield and pump capacity is reflected in Figure 8.

Figure 8
Reservoir Elevation vs. Time

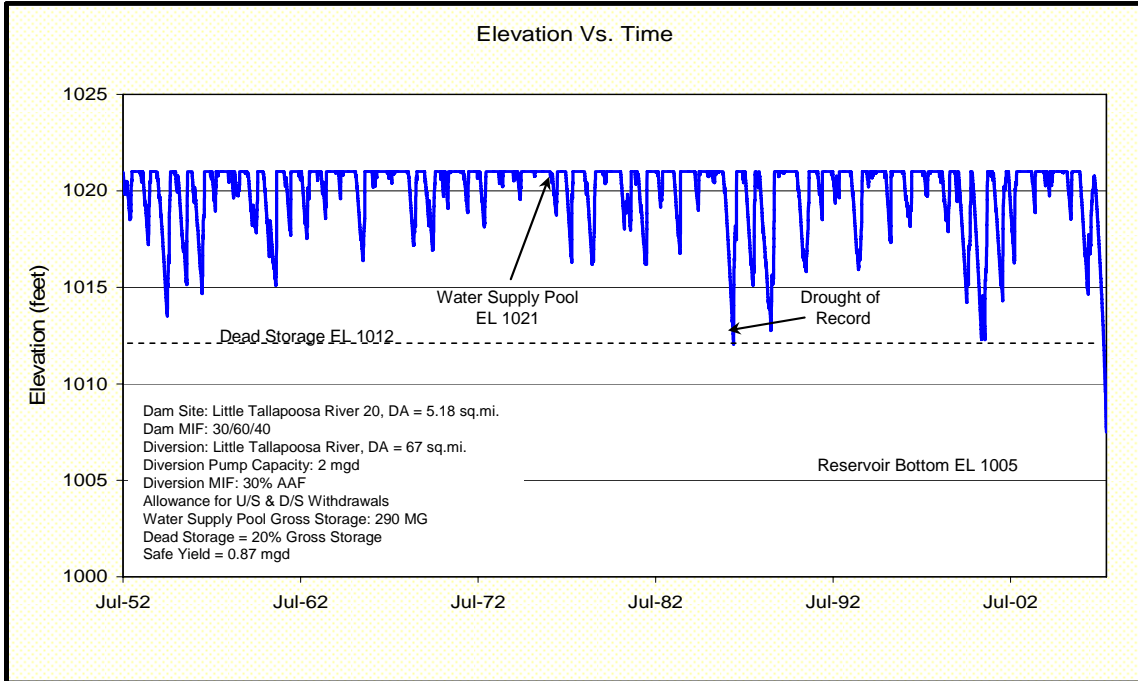

ENVIRONMENTAL CONSIDERATIONS

Preliminary Studies

To evaluate the potential environmental impacts, permitting and compensatory mitigation associated with Little Tallapoosa River 20, preliminary ecological studies were conducted by JIG. These studies consisted of a desktop survey and wetland approximation field surveys to estimate wetlands and streams occurring within the project area. While this evaluation is not sufficient for Clean Water Act Section 404 permitting, field surveys add increased confidence to the desktop evaluation. All estimates of jurisdictional waters, permitting requirements, and compensatory mitigation requirements/cost estimates presented herein are very general and preliminary in nature. Detailed studies would be necessary to definitively determine permitting requirements.

Prior to conducting field surveys, desktop evaluations were performed with available data resources including the U.S. Geological Survey 7.5-minute topographic maps and U.S. Fish and Wildlife Service (USFWS) National Wetland Inventory (NWI) maps. JIG ecologists then performed a reconnaissance-level site visit to Little Tallapoosa River 20 site to verify and supplement the desktop evaluation. Subsequent to field surveys, observations were transcribed into an ArcView GIS database for analysis. Preliminary estimates of jurisdictional waters (i.e., wetlands, streams, open waters) occurring within the Little Tallapoosa River 20 project area are provided below.

Wetlands

The *Classification of Wetlands and Deepwater Habitats of the United States* (Cowardin Classification System) defines the Palustrine System as all nontidal wetlands dominated by trees, shrubs, persistent emergent vegetation, emergent mosses or lichens, and all such wetlands that occur in tidal areas where salinity is less than 0.5 percent. It also includes wetlands lacking such vegetation, but with all of the following four characteristics: 1) area less than 20-acres; 2) the lack of active wave-formed or bedrock shoreline; 3) water depth in the deepest part of basin less than 6.6 feet at low water; and 4) salinity due to ocean-derived salts less than 0.5 percent.

The Lacustrine System includes wetlands and deepwater habitats with all of the following characteristics: 1) situated in a topographic depression or a dammed river channel; 2) lacking trees, shrubs, persistent emergent vegetation, emergent mosses or lichens with greater than 30-percent areal coverage; and 3) total area exceeds 20 acres. Wetlands and deepwater habitats less than 20-acres are also included in this system if an active wave-formed or bedrock shoreline feature makes up all or part of the boundary, or if the water depth in the deepest part of the basin exceeds 6.6 feet at low water.

Office and field reviews determined that approximately 102 acres of palustrine wetlands and approximately 37 acres of lacustrine/palustrine open waters exist within the Little Tallapoosa River 20 project area. Cowardin classifications of the wetland systems range from palustrine forested to palustrine emergent with hydrologic regimes ranging from saturated to seasonally flooded.

Streams

The Cowardin Classification System defines lower perennial streams as low gradient streams with slow water velocities and substrates comprised mainly of sand and mud. Intermittent streams are defined as streams flowing for only part of the year. When water is not flowing, it may remain in isolated pools or surface water may be absent. Ephemeral streams flow only in direct response to precipitation and do not receive groundwater contributions.

Office and field reviews indicate that approximately 11,572 linear feet of lower perennial streams and approximately 8,510 linear feet of intermittent streams are located within the maximum reservoir pool limits of Little Tallapoosa River 20. Ephemeral streams were not identified due to the preliminary nature of the studies. Refer to Figure 9 for locations of these jurisdictional features.

Cultural Resources

Review of existing cultural resources information indicated one identified cultural resource site (Little Tallapoosa Structure 20 Dam) within the maximum reservoir pool limits of Little Tallapoosa River 20. A Phase I Cultural Resources Survey (conducted to the standards of Section 106 of the National Historic Preservation Act) and coordination with Georgia Historic Preservation Division would be required to determine potential Cultural Resources impacts for any proposed reservoir project.

Threatened and Endangered Species

Review of existing threatened and endangered species information identified six state protected species documented from Carroll County, Georgia and consists of three faunal and three floral species. The Georgia Department of Natural Resources – Non-game Conservation Section lists the occurrence of a state endangered species, the stippled studfish (*Fundulus bifax*), within the maximum reservoir pool limits of Little Tallapoosa River 20. Specialized aquatic surveys would be required to definitively determine the presence/absence of this species within the project area. Refer to Table 5 for a summary of protected species located in Carroll County and potential habitat for these species within the maximum reservoir pool limits.

Figure 9
Jurisdictional Areas Location Map

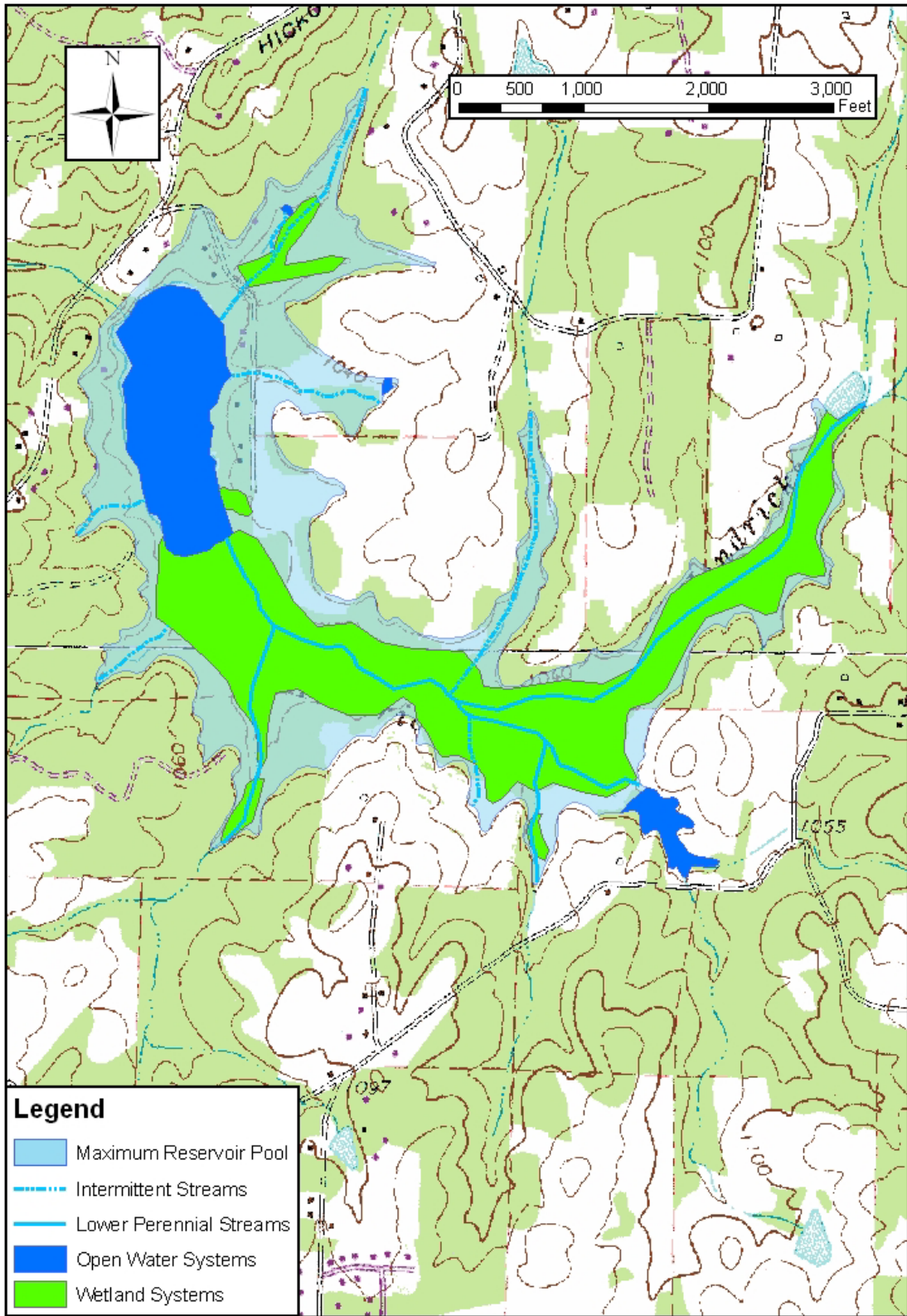

Table 5
Summary of Protected Species for Carroll County, Georgia

Scientific Name	Vernacular Name	Federal Status	State Status	Habitat Present (Yes/No)	Preferred Habitat
Faunal species					
<i>Cyprinella callitaenia</i>	bluestripe shiner	NA	T	No	flowing areas in large alluvial rivers with open, sand or rock bottomed channels with little or no aquatic vegetation
<i>Notropis hypsilepis</i>	highscale shiner	NA	T	Yes	flowing areas of small to medium streams over sand or bedrock substrates
<i>Fundulus bifax</i>	stippled studfish	NA	E	Yes	pools, stream margins, and backwaters over sandy or rocky substrates within the Coosa and Tallapoosa River systems
Floral species					
<i>Platanthera integrilabia</i>	white fringeless orchid	CS	T	Yes	red maple-blackgum swamps; sandy, damp stream margins; seepy, rocky, thinly vegetated slopes
<i>Schisandra glabra</i>	bay star-vine	NA	T	Yes	twining in subcanopy and understory tress/shrubs in rich alluvial woods
<i>Waldsteinia lobata</i>	Piedmont barren strawberry	NA	T	No	rocky woods along streams with mountain laurel

T= threatened, E= endangered, CS= candidate species, NA= not applicable

Trout Streams

Review of available resources did not indicate any primary or secondary trout streams within the maximum reservoir pool limits of Little Tallapoosa River 20.

303(d) and 305(b) Listed Streams

Review of available resources did not indicate any 303(d) or 305(b) listed streams within the maximum reservoir pool limits of Little Tallapoosa River 20.

Section 404/401 Permitting

The U.S. Army Corps of Engineers (USACE) regulates the discharge of dredged or fill material into the Nation's Waters under Section 404 of the Clean Water Act. Construction of an impoundment and flooding jurisdictional streams/wetlands is regulated by the USACE. Two types of permits are available through the USACE: Nationwide and Individual Permits. Nationwide Permits (NWP) have been established previously by the Chief of Engineers for projects that have minimal cumulative impacts to the Nation's Waters. Examples of the most commonly used NWPs include site development, minor road crossings, maintenance activities, and utility line discharges. Specific criteria and conditions were established that must be satisfied prior to obtaining authorization of a NWP from the USACE. In addition, the Savannah District of the USACE issued Final Nationwide Permit Regional Conditions effective May 11, 2007.

Individual Permits (IP) are required for projects having more than minimal cumulative adverse impacts on the Nation's waters. The development of a water supply reservoir would typically require an IP. IP's involve significantly more information, documentation, and coordination with regulatory agencies and are considerably more difficult to acquire than a NWP. Prior to coordination with the USACE regarding the construction of an impoundment, required information would consist of, but not be limited to, the following information:

- Justification of Purpose and Need for the project
- Alternatives analysis of other water supply options evaluated to meet the need
- Wetland delineation with surveyed boundaries of USACE jurisdictional waters
- Phase I cultural resources and protected species surveys
- Detailed description of proposed project and proposed impacts to jurisdictional waters
- Detailed analysis of flow releases documented with population analysis and system modeling
- Avoidance and minimization of jurisdictional waters analysis
- Identification of adjacent property owners
- Development of a conceptual compensatory mitigation plan

Following completion of these items, a complex project meeting would typically be scheduled with the USACE Northern Area Section Office (Morrow, GA) to present the

proposed project. Subsequent to the meeting, and if a project is tentatively accepted by the regulatory agencies, formal application and preparation of an IP would start. Following submittal of an IP, the application must be advertised for public comment. The USACE prepares the public notice, which includes detailed applicant information such as site location, proposed impacts, cultural resources, protected species, and proposed mitigation. The public notice would be advertised for 30 days and is also submitted to regulatory agencies including the Environmental Protection Agency (EPA) and USFWS, adjacent property owners, and to the USACE general mailing list. Applicants will be required to respond to inquiries received during the public notice process. Public hearings could be required if substantial adverse comments are received from the coordinating agencies or the public. Additional information and permitting required would consist of a Section 401 Water Quality Certification from the Georgia Environmental Protection Division (EPD). This certification must be issued for an IP to be valid. Depending on the level of impacts associated with the proposed reservoir, an Environmental Assessment or Environmental Impact Statement could be required by the USACE as well. Based on previous project experience, the level of controversy and environmental issues raised during agency and public review, a typical new reservoir project may require permitting times of 5 years or more.

The expansion of an existing reservoir could potentially facilitate the Section 404 permitting process when compared to the construction of a new impoundment. This is especially true for issues such as alternatives analysis, avoidance and minimization, and aquatic organism passage in that many or most potential impacts have already occurred. However, the steps of the overall Section 404 permitting process would still need to be followed, and historically reservoirs have encountered significant regulatory and public challenges, regardless of the presence/absence of an existing impoundment.

Compensatory Mitigation

To determine the amount mitigation potentially required for jurisdictional impacts within the Little Tallapoosa River 20, the USACE's Standard Operating Procedure (SOP) for Compensatory Mitigation (March 2004) was utilized. The SOP uses a series of factors such as location, type, existing condition, type of impact, etc. to generate a multiplying "factor." That factor is then multiplied by the impact area (acreage or linear footage) to calculate the required mitigation credits. To determine an average factor for jurisdictional areas associated with the Little Tallapoosa River 20, various conditions observed during the field surveys were utilized. *However, it is imperative to note that this document only serves as a guideline if impacts do not exceed 5,000 linear feet of stream or ten acres of wetland impacts.* Potential impacts for the Little Tallapoosa River 20 would significantly exceed this threshold and actual compensatory mitigation requirements would likely be substantially different from SOP estimates. Currently, the USACE Savannah District Office is developing a new SOP for large-scale projects focused on reservoirs. It is anticipated that this SOP would be issued mid-2008.

Utilizing the 2004 SOP and the approximated acreage and linear feet of jurisdictional waters located within the Little Tallapoosa River 20 project area, an estimate of compensatory mitigation credits can be determined. Multiplying factors used for this

analysis include: 6.7 for wetland systems, 5.7 for open waters, 12.7 for lower perennial streams, and 7.6 for intermittent streams. This factor was then multiplied by the acreage/ linear footage to determine an estimated number of mitigation credits required. The number of credits was then multiplied by an average credit price to estimate the final estimated compensatory mitigation cost associated with the Little Tallapoosa River 20. Refer to Table 6 contained in the following section entitled “Project Construction Cost Estimate Narrative” for estimated impacts to jurisdictional waters and an estimate of mitigation credits required and associated costs.

Stream Buffer Variance

The Georgia Erosion and Sedimentation Act of 1975 (GESA), as amended, requires that a 25-foot vegetated buffer be maintained along all state waters. Any land disturbing activities within the buffer would require obtaining a stream buffer variance from the EPD. The local issuing authority is responsible for determining if state waters are on-site and is responsible for determining if a stream buffer variance is required.

The GESA has several exemptions including public water system reservoirs. Attendant features such as pipelines and roadways, would be exempt if stream crossings are nearly perpendicular.

EPD Water Withdrawal Permit

Georgia EPD requires a permit for withdrawal of 100,000 gallons per day or more of either surface water or ground water. In addition to justification of need for water for up to 50 years in the future, water withdrawal permits typically require the preparation of water conservation, drought contingency, water supply/watershed protection, and reservoir management plans. A public hearing may be required as part of the withdrawal permitting process. EPD requires that its comments on the component plans be addressed before moving forward with issuing the water withdrawal permit. Based on previous permitting experience, a water withdrawal permit can be obtained within 5 to 7 months, depending on EPD’s review time and the extent of their comments.

Source Water Protection Plan

Amendments to the Federal Safe Drinking Water Act (SDWA) have brought about a new approach for ensuring clean and safe drinking water served by public water supplies in the United States. Management of a drinking water source now requires a Source Water Protection Plan. This plan basically defines watershed management strategies for ensuring that the water supply is not compromised by potential pollutant sources. Typically these sources are unmanaged development, but they can also include industrial sources that can potentially contaminate the water supply. The entity that operates this reservoir for water supply would be required to produce and implement the Plan. The Plan should also address any source water from outside the reservoir watershed that would be used to fill the reservoir, i.e., pumped/storage sources. The cost and schedule for producing a Source Water Assessment and the corresponding Source Water Protection Plan have not been included in any of the estimates presented in the report.

PROJECT CONSTRUCTION COST ESTIMATE NARRATIVE

Dam and Reservoir

The construction cost estimate for the proposed dam was based upon the general description provided in the background section of the report. Additionally, the following assumptions were made regarding the geometry of the dam.

- Upstream slope of 3H to 1V
- Downstream slope of 3H to 1V
- Upstream slope wave action protection in the form of riprap from 30 feet below the crest of the dam to 5 feet below the crest of the dam. Riprap supported by a berm located 30 feet below top of dam.
- Downstream slope having nearly horizontal 12-foot wide berms at 30-foot vertical intervals to control surface water runoff and erosion
- Crest of dam having a width of 25-feet

In addition to the above geometric considerations, the following internal drainage configurations were also considered in the estimation of construction costs.

- Chimney drain located at the downstream edge of the crest
- Trench drain located at 1/3 the distance from the downstream toe to the crest

A plan view and cross section of the proposed dam is provided in Figures 10 and 11.

Contained below are the items estimated to develop the construction cost estimate. We caution that the quantities and associated prices are based upon limited engineering evaluation and will likely change as the project proceeds into detailed evaluation and design.

Mobilization and Demobilization

Mobilization and demobilization is a lump sum item estimated at 6 percent of the unit rate sum of the construction items.

Erosion and Sedimentation Control

Erosion and sedimentation control is a lump sum item estimated at 2 percent of the sum of unit rate construction items.

Control of Water

Control of water is a lump sum item estimated at 3 percent of the sum of unit rate construction items. This item includes the control of both surface water and groundwater and will likely consist of stream diversion, cofferdam construction and maintenance, pumping, and well points, as well as any other means of controlling water during construction.

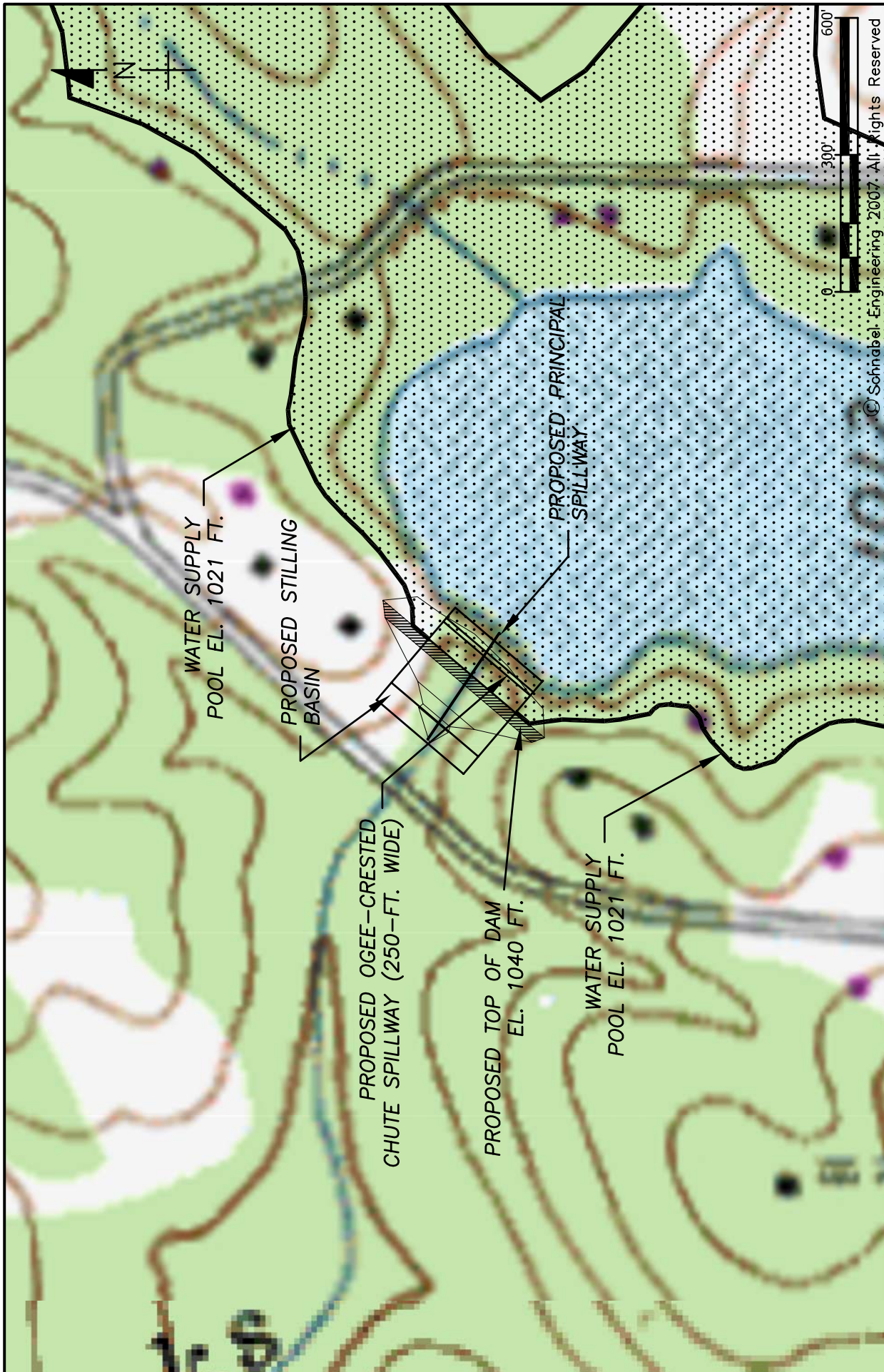

© Schnabel Engineering, 2007. All Rights Reserved

	<p>NRCS WATERSHED DAM ASSESSMENT Little Tallapoosa River No. 20</p>	<p>PROPOSED PLAN VIEW</p>
<p>PROJECT NO. 07170030.01 FIGURE 10</p>		

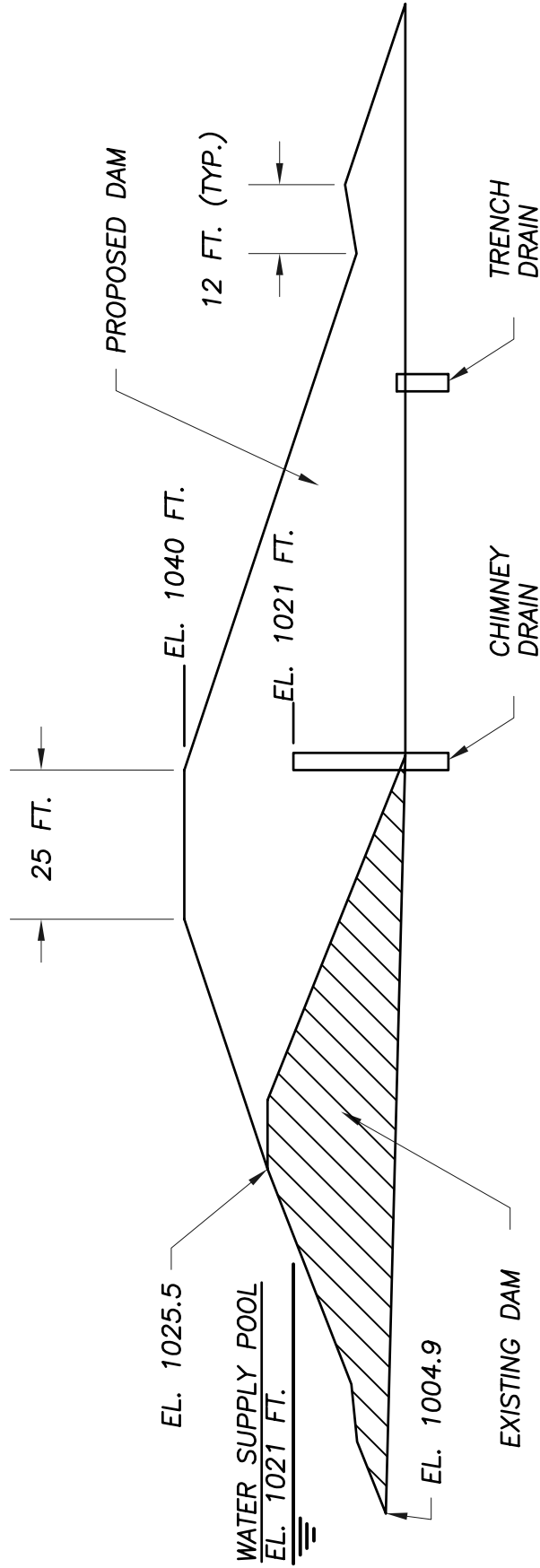

© Schnabel Engineering 2007 All Rights Reserved

<p>TYPICAL SECTION</p>	<p>NRCS WATERSHED DAM ASSESSMENT LITTLE TALLAPOOSA RIVER NO. 20</p>	
<p>PROJECT NO. 07170030.01 FIGURE 11</p>		

Clearing

Clearing is a unit rate item measured in acres associated with the removal of trees and other vegetation from the reservoir. The estimated area of clearing was assumed to be equal to the surface area of the reservoir at the normal pool elevation.

Clearing and Grubbing

Clearing and grubbing is a unit rate item measured in acres associated with the removal of trees, other vegetation, and associated root mats in the areas to receive structural fill or concrete. The estimated area of clearing and grubbing was assumed to be equal to the footprint of the proposed dam plus an additional 50-foot perimeter around the proposed dam.

Earth Fill

Earth Fill is a unit rate item measured in cubic yards. The computed volume of earth fill represents the estimated quantity required to construct the dam as described herein. The estimated quantity was computed using an AutoCad Civil 3D computer model based on the proposed grading and existing topography. In addition to the proposed embankment earth fill, foundation excavation backfill was calculated (see Excavation, Common for details) and added to the embankment earth fill to determine the total quantity of earth fill.

Drain Fill

Drain Fill is a unit rate item measured in cubic yards. The computed volume of drain fill represents the estimated quantity of fine and coarse-grained drain material required to construct the internal drainage system as described herein. For the purposes of this study, no differentiation was made between fine and coarse drain fill. In addition, the quantity for the trench drain was assumed to be equal to half of the chimney drain quantity. The chimney drain was assumed to have a top elevation equal to the proposed normal pool elevation and a bottom elevation approximated at the limits of the foundation excavation. The chimney drain was assumed to have a width of three feet and run the length of the dam from one abutment, into the floodplain, and up the other abutment tying into residual soils.

Excavation, Common

Excavation, Common is a unit rate item measured in cubic yards associated with the removal of unsuitable material (soils) within and adjacent to the footprint of the proposed dam. The volume of common excavation was calculated by approximating the surface area of the floodplain within the limits of clearing and grubbing as well as the depth of excavation within the same area. The surface area of the floodplain was approximated using available topographic maps. The depth of excavation was estimated from the boring data included in the design plans for the existing dam.

Riprap

Riprap is a unit rate item measured in tons. The computed weight of riprap represents the estimated quantity required to construct the wave-action berm as described herein. Riprap was assumed to be placed on the upstream slope of the dam. The section of riprap was assumed to extend 30 vertical feet, have a thickness of about 2-¾ feet, and traverse the length of the proposed dam.

Permanent Turf Establishment

Permanent Turf Establishment is a unit rate item measured in acres associated with the establishment of a permanent turf at the conclusion of construction activities for the proposed dam. The estimated area of permanent turf establishment was assumed to be equal to the estimated area of clearing and grubbing.

Concrete, Class 4000

Concrete, Class 4000 is a unit rate item measured in cubic yards associated with the construction of the reinforced concrete auxiliary chute spillway. The volume of concrete was estimated by comparing the proposed auxiliary spillway drop in elevation and width to the drops in elevation and widths of constructed reinforced concrete chute spillways. A relationship was developed between the drop in elevation and width of the constructed spillways and the required quantity of concrete. This relationship was applied to the proposed dam to estimate the quantity of concrete.

Principal Spillway Reinforced Concrete Pressure Pipe

Reinforced Concrete Pressure Pipe (RCPP) is a unit rate item measured in feet. The computed length of RCPP represents the estimated quantity required to construct the principal spillway conduit described herein. The RCPP was assumed to be placed through the base of the proposed dam from the upstream toe to the downstream toe. The diameter of the pipe was assumed to be equal to the diameter of the pipe in the existing dam.

Concrete, Class 3000 (mass)

Concrete, Class 3000 is a unit rate item measured in cubic yards associated with the construction of the concrete cradle beneath the principal spillway pipe. The concrete cradle was assumed to be designed as a Soil Conservation Service Type A2 cradle and run the length of the principal spillway pipe minus ten feet.

Reinforced Concrete Riser

The Reinforced Concrete Riser is a lump sum item associated with the construction of the reinforced concrete principal spillway structure. The cost was estimated by comparing the proposed principal spillway riser height to the heights of constructed reinforced concrete riser structures. A relationship was developed between the height of the constructed spillways and the cost to construct them. This relationship was utilized to estimate the cost of the proposed riser structure.

Land Acquisition

The costs associated with land acquisitions are unit rate items based upon the number of acres that will need to be purchased at the top-of-dam elevation, the number of acres that will need to be managed for a 150-foot buffer around the normal pool, and the number of houses that will need to be purchased. For the purposes of the buffer management, only the portions of the buffer above top-of-dam elevation were considered. The costs to purchase the land were estimated based upon available records of recent land sales. The cost to manage the buffer was assumed to be 60 percent of the land purchase cost. The cost of each structure impacted was assumed to be \$200,000.

Roadway Relocation

To construct the proposed project, four roads will be impacted. These roads may need to be raised, relocated, or modified to accommodate the new reservoir; however, no consideration was given to the relocation of the roads in this study. A more detailed evaluation would need to be performed to evaluate the impact on existing roadways and the associated cost.

Pump Station and Pipeline Cost Estimation

The pump storage location for Little Tallapoosa River Reservoir 20 is located on the Little Tallapoosa River, upstream of its confluence with Hendricks Creek. The reservoir is located approximately 0.75 miles upstream of the confluence on Hendricks Creek. With a water supply pool elevation of 1021 feet, Reservoir 20 has an average day yield of approximately 0.87 MGD. A 12-inch ductile iron pipeline was selected to carry water from the pump storage location to the reservoir. This pipeline is approximately 0.9 miles in length and will pump water from the storage location elevation of 990 feet to the 1021 feet height of the reservoir water surface. A cascading structure will need to be constructed where the pipe comes into the reservoir to provide aeration and erosion control.

Two 2-MGD pumps were selected at the pump storage location to pump water to the reservoir. This gives a firm pumping capacity of 2-MGD, which is roughly twice the daily yield of the reservoir, the standard assumption for pump capacity. This pumping capacity will allow the reservoir to remain stable during times of peak water demand, as well as give redundancy in the case of failure in one of the pumps. An access road will need to be constructed in order to construct and maintain the pumping station on the Little Tallapoosa River. This road, shown on Figure 12, will run approximately 0.44 miles from Windom Drive. The cost opinion for these components is found in the appendix.

Figure 12
Project Location Map

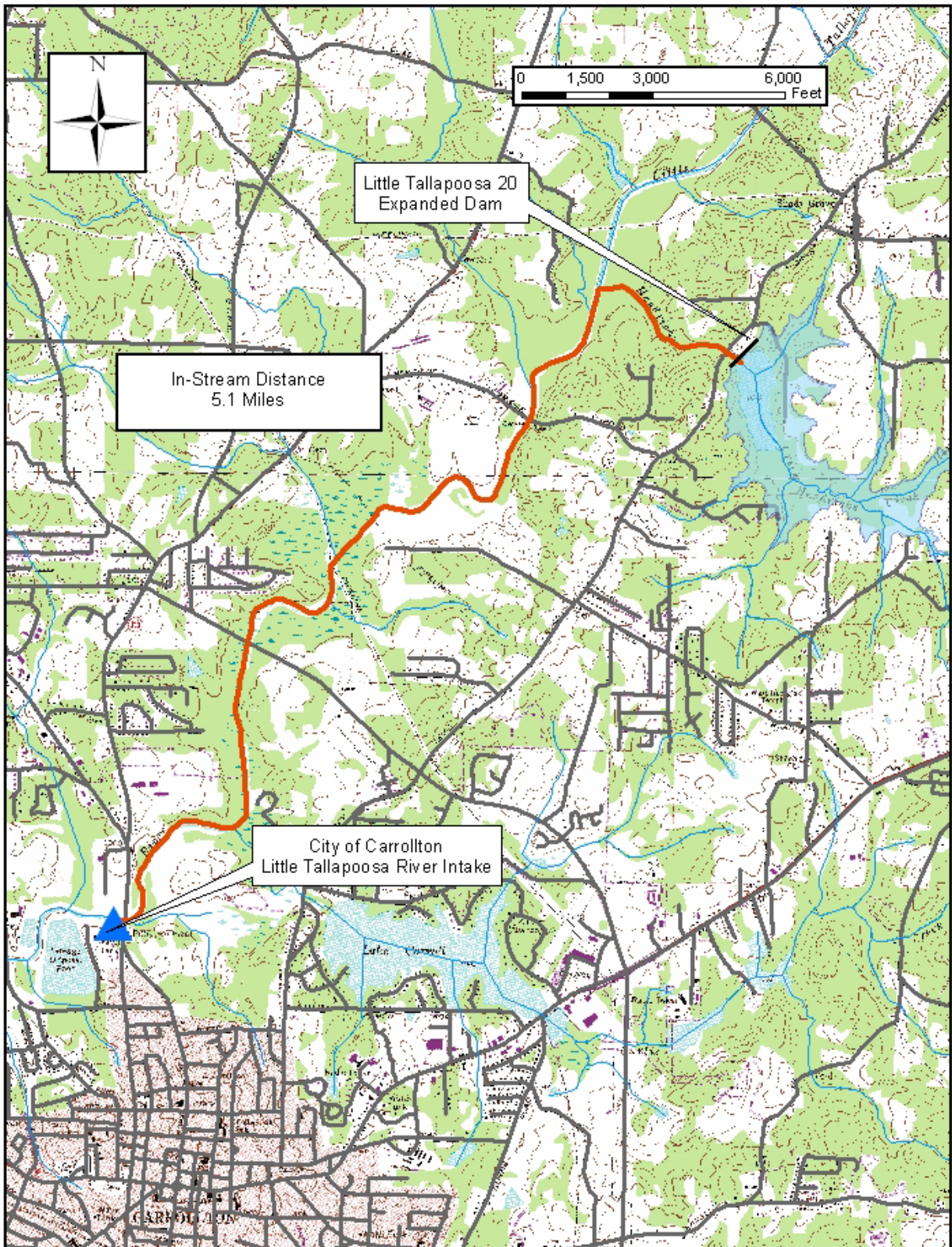

Compensatory Mitigation

The simplest mitigation option is typically purchasing credits from a bank. Compensatory mitigation credits may be purchased from an approved mitigation bank or through the Georgia Land Trust Service Center if a bank is not available within the project area. Based on recent projects, wetland credits range from \$7,000-\$10,000 per credit and stream credits range from \$70-\$110 per credit. An option to purchasing credits is to obtain credits by conducting on-site restoration or preservation of jurisdictional waters.

**Table 6
Little Tallapoosa River 20 Estimated Impacts and Overall Mitigation Banking
Cost Analysis**

Impact Type	Estimated Impact Acres/Linear Feet	Projected Credits Needed	Projected Cost* \$90/stream credit \$7,500/wetland credit
Wetland	101.76 A.	682	\$5,115,000
Intermittent Stream	8,510 l.f.	64,676	\$5,820,840
Lower Perennial Stream	11,572 l.f.	146,964	\$13,226,760
Open Water	36.63 A.	209	\$1,567,500
Total	138.39 acres/20,082 lf	891 wetland / 211,640 stream**	\$25,730,100

*Cost is based on recent quotes from banks within the Upper Tallapoosa Basin. Actual banking price may be higher or lower than estimated depending on the date of purchase and credit availability.**Total required credits calculated using the March 2004 Standard Operating Procedure mitigating guidelines established by the US Army Corps of Engineers.

Estimated Project Construction Cost

The total project cost is estimated at \$71,000,000. Table A-5, located in the appendix, shows an itemized breakdown of the costs associated with enlarging the existing dam and reservoir. These costs are estimates and are based on multiple assumptions.

APPENDIX

FIGURES

Figure A-1	Gage Station Flows – Regression Analysis
Figure A-2	Stage Storage / Stage Area Curves
Figure A-3	Regression Equations for Area to Storage and Depth to Storage
Figure A-4	Storage vs. Time and Elevation vs. Time for Assumed Safe Yield

TABLES

Table A-1	Summary of Opinion of Probable Construction Costs for Pumping Facilities and Pipelines
Table A-2	Opinion of Probable Construction Costs – River Intake and Pump Station
Table A-3	Opinion of Probable Construction Costs – 30-inch Raw Water Line
Table A-4	Opinion of Probable Construction Costs – Reservoir Inlet Structure
Table A-5	Total Project Opinion of Cost

Little Tallapoosa River below Bowden (USGS 02413210) vs Tallapoosa River near Heflin (USGS 02412000)

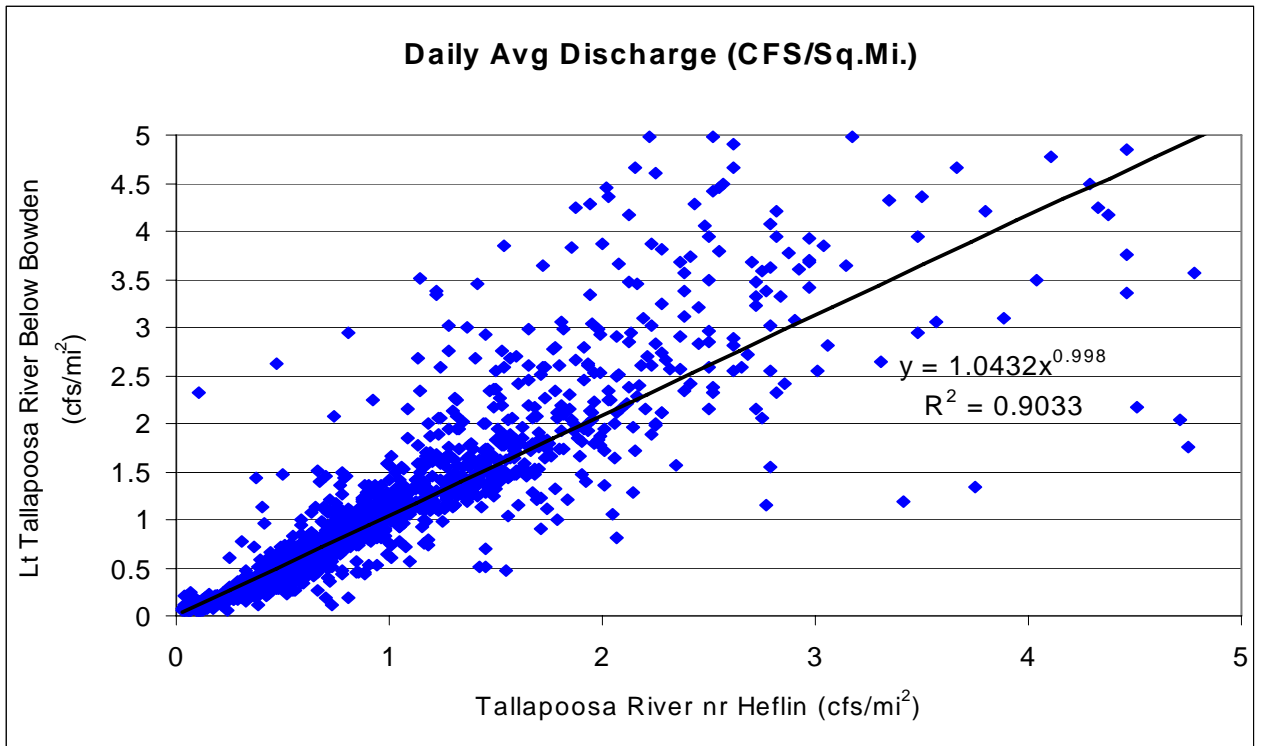
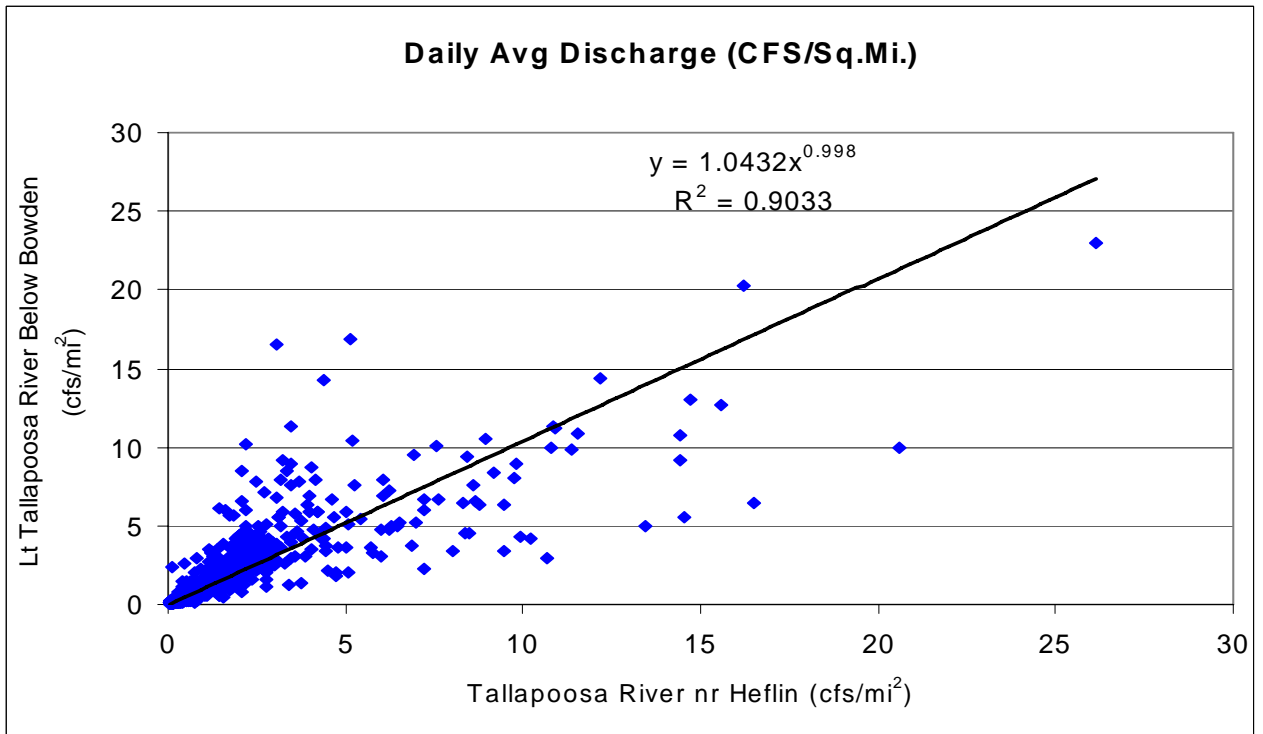

Little Tallapoosa 20 Area and Storage Curves

Elev.	Area Acres	Area mg/in	Inc. Vol. A-FT	Cumulative Vol A-FT	M Gal.
1005	0.0	0	0	0	0
1010	33.6	1	84	84	27
1020	93.3	3	666	750	245
1040	276.2	7	3695	4446	1449
1060	609.0	17	8853	13298	4334
1080	1129.1	31	17382	30680	9999

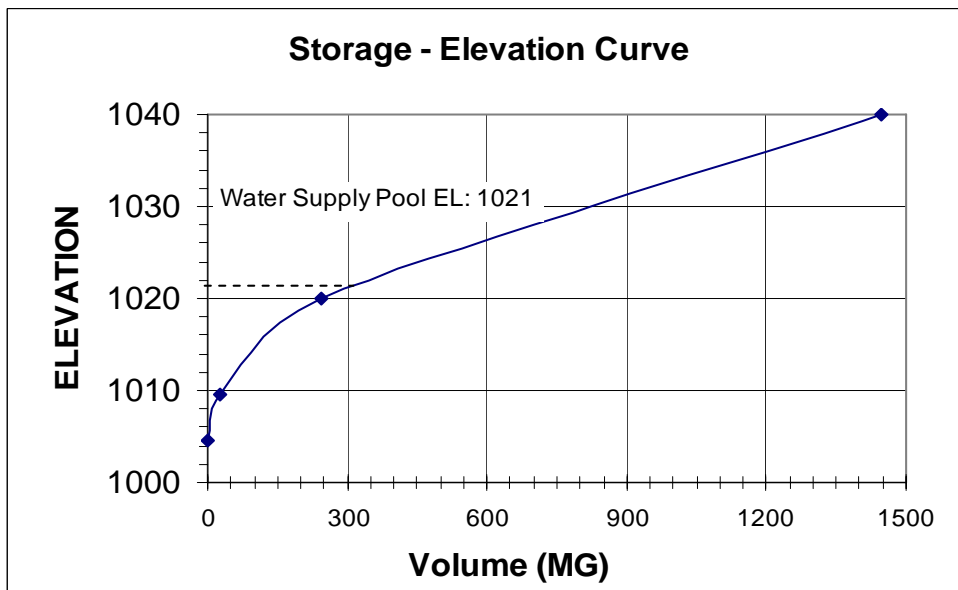
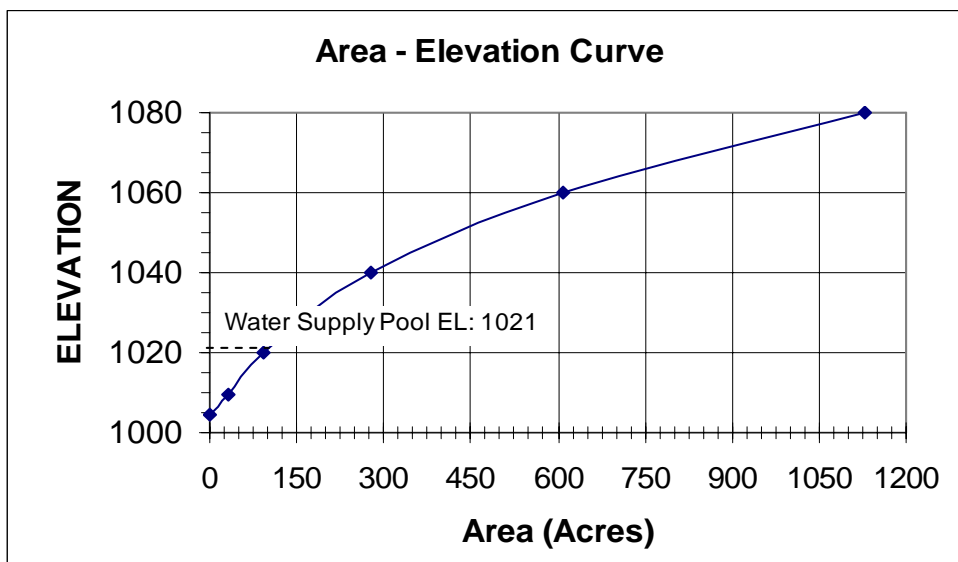

Little Tallapoosa River 20

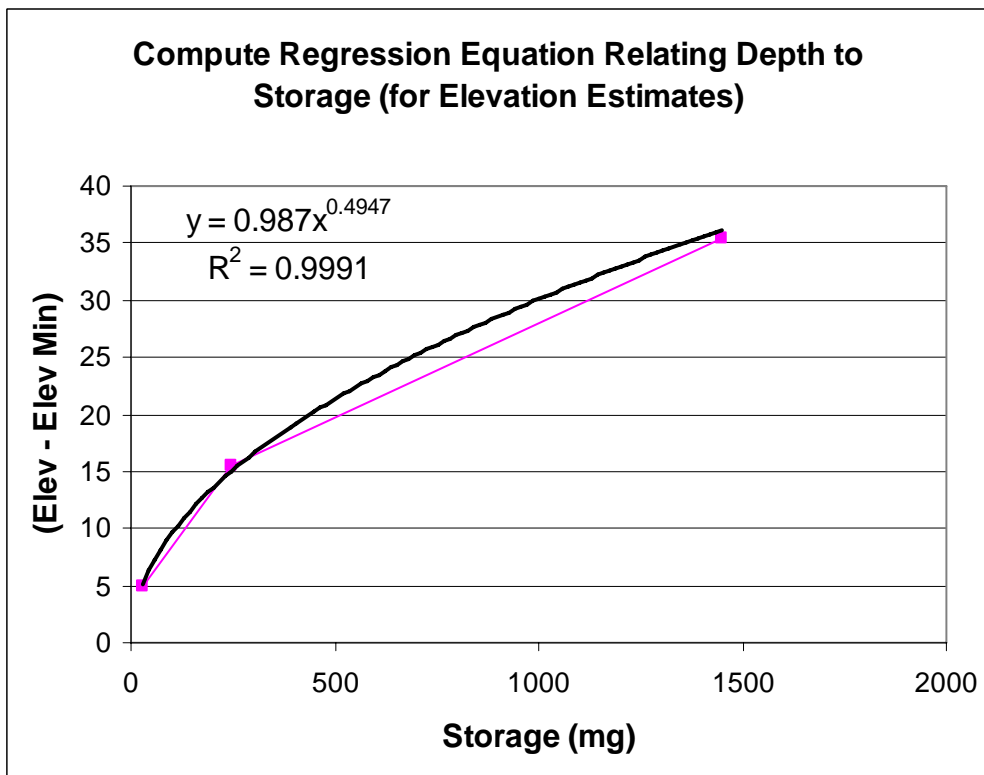
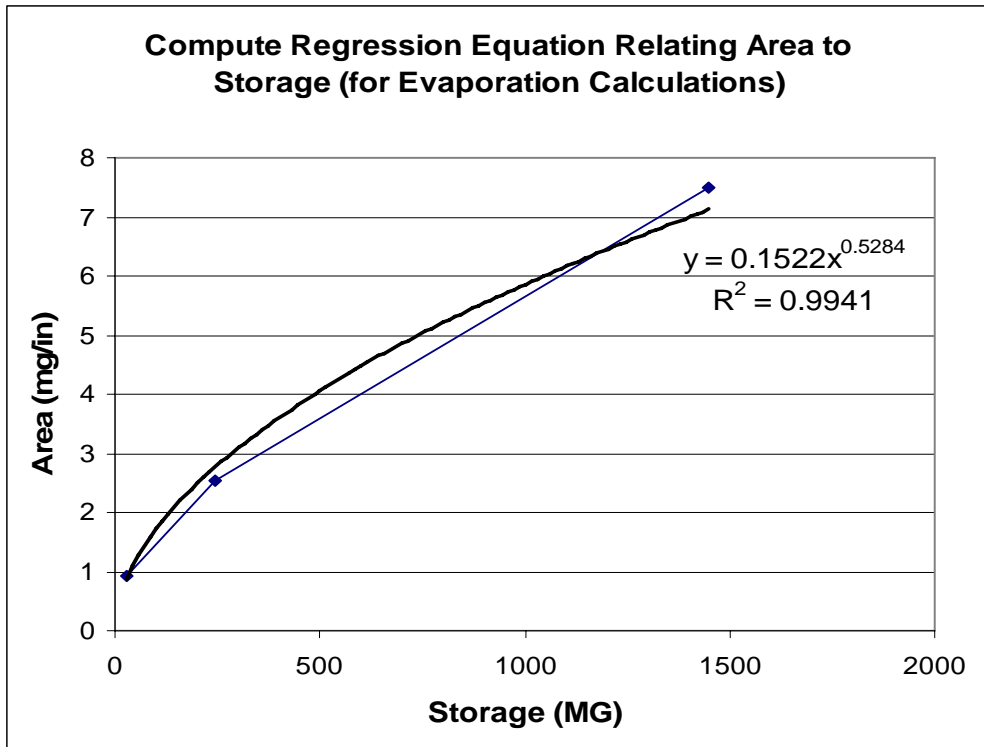
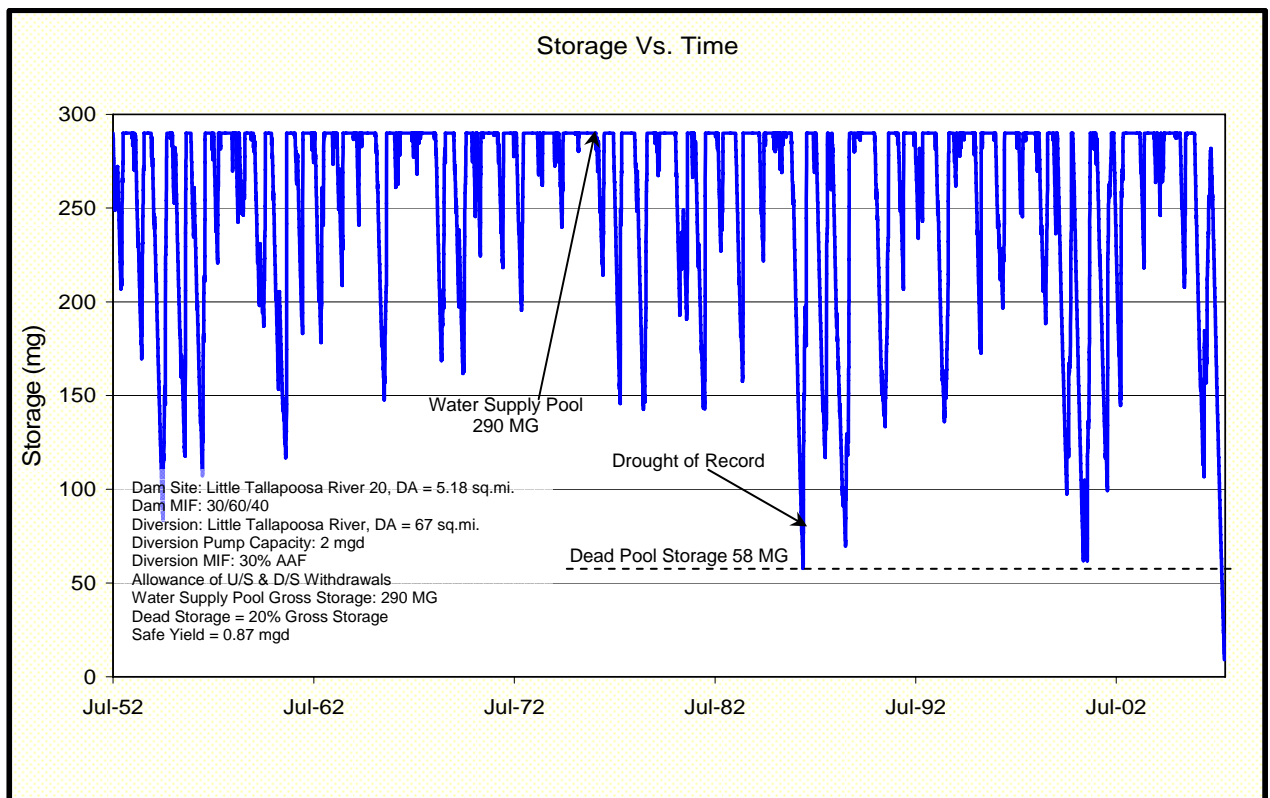
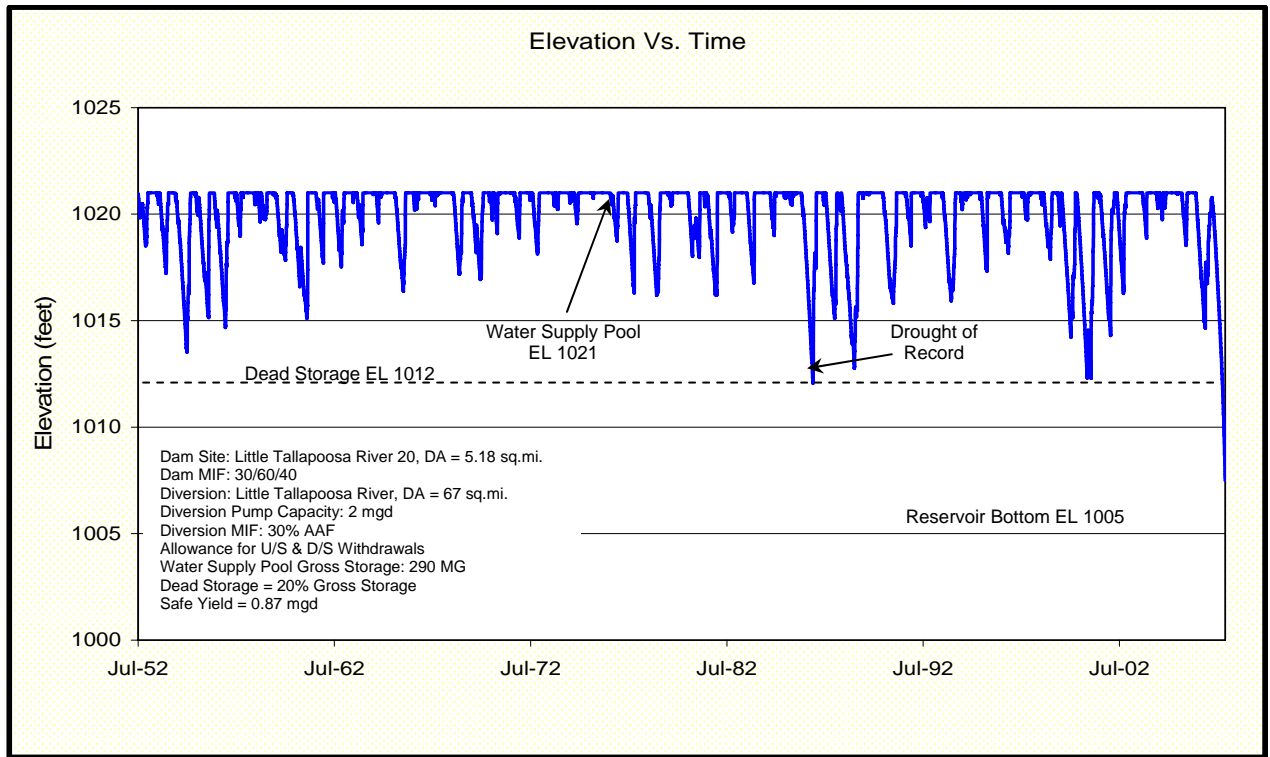

Figure A-4

Little Tallapoosa River 20



WATERSHED DAM ASSESSMENT - LITTLE TALLAPOOSA RIVER 20
Carroll County, Georgia (7194-001)
OPINION OF PROBABLE CONSTRUCTION COST ESTIMATE - CONCEPTUAL LEVEL
Summary by Division

TABLE A-1

Division	01 - Intake and Pump Station and Access Road	02 - 12 - inch Raw Water Force Main and Venturi Vault	03 - Reservoir Inlet Structure	TOTAL	% of Total	
1	\$0.54	\$0.03	\$0.05	\$0.63	9.16%	LITTLE TALLAPOOSA RIVER 20
2	\$0.88	\$0.00	\$0.04	\$0.93	13.51%	
3	\$0.59	\$0.01	\$0.27	\$0.87	12.75%	
4	\$0.05	\$0.00	\$0.00	\$0.05	0.76%	
5	\$0.02	\$0.00	\$0.00	\$0.02	0.33%	
6	\$0.00	\$0.00	\$0.00	\$0.00	0.00%	
7	\$0.01	\$0.00	\$0.00	\$0.01	0.19%	
8	\$0.03	\$0.00	\$0.00	\$0.03	0.44%	
9	\$0.05	\$0.00	\$0.00	\$0.05	0.73%	
10	\$0.00	\$0.00	\$0.00	\$0.00	0.00%	
11	\$0.95	\$0.00	\$0.06	\$1.01	14.68%	
12	\$0.00	\$0.00	\$0.00	\$0.00	0.00%	
13	\$0.00	\$0.00	\$0.00	\$0.00	0.00%	
14	\$0.07	\$0.00	\$0.00	\$0.07	1.03%	
15	\$0.30	\$0.30	\$0.01	\$0.62	8.97%	
16	\$0.94	\$0.02	\$0.00	\$0.96	14.01%	
17	\$0.16	\$0.02	\$0.00	\$0.18	2.59%	
Structure Contingency	\$0.46	\$0.00	\$0.00	\$0.46	6.72%	
Markup	\$0.81	\$0.06	\$0.09	\$0.97	14.13%	
Structure Total (without Contingency)	\$5.88	\$0.46	\$0.53	\$6.86	100.00%	
Project Contingency	\$1.76	\$0.14	\$0.16	\$2.06	30.00%	
Structure Total (with Contingency)	\$7.64	\$0.59	\$0.68			
*All Figures are in Millions				TOTAL	\$8.92 *	

WATERSHED DAM ASSESSMENT - LITTLE TALLAPOOSA RIVER 20
Carroll Georgia (7194-001)

01
 DECEMBER 2007

OPINION OF PROBABLE CONSTRUCTION COST ESTIMATE - CONCEPTUAL LEVEL

TABLE A-2

01 - River Intake and PS

No.	Spec. Sect.	Description	Unit	Qty	Labor \$\$		Material \$\$		Equipment \$\$		Subcontractor \$\$		Total
					Unit	Total	Unit	Total	Unit	Total	Unit	Total	
01 - Little Tallapoosa River 20: River Intake and Pump Station					2 - Channel Intake Pump Station				Pump Station Firm Capacity is 2 MGD				
Div 1													
1	1000	General Conditions	LS	1		\$195,000		\$154,300		\$195,000		\$0	\$544,300
Div 2													
2	2200	Earth Work	LS	1	\$9,700.00	\$9,700	\$6,000.00	\$6,000	\$2,478.00	\$2,480	\$222,000.00	\$222,000	\$240,180
3		Access Road	LF	2300		\$0		\$0		\$0	\$110.00	\$253,000	\$253,000
4		Creek Crossing	EA	2		\$0		\$0		\$0	\$50,000.00	\$100,000	\$100,000
5	2831	10' Galv. Chain Link Fence	LF	3000		\$0		\$0		\$0	\$30.00	\$90,000	\$90,000
6	2831	Dewatering / Pre-Excavation Preparation	LS	1	\$50,000.00	\$50,000	\$20,000.00	\$20,000	\$100,000.00	\$100,000	\$30,000.00	\$30,000	\$200,000
Div 3													
7	3250	Water Stop	LF	500	\$1.25	\$630	\$2.00	\$1,000		\$0		\$0	\$1,630
8	3300	Concrete Bridge	SF		\$2.00	\$0		\$0	\$3.50	\$0	\$20.00	\$0	\$0
9	3300	Concrete	LS	1	\$184,786.00	\$184,790	\$344,736.00	\$344,740	\$58,270.00	\$58,270	\$0.00	\$0	\$587,800
Div 4													
10	4210	Brick Veneer	SF	2400		\$0		\$0		\$0	\$14.50	\$34,800	\$34,800
11	4220	Concrete Masonry Unit - Reinforced	SF	2400		\$0		\$0		\$0	\$7.25	\$17,400	\$17,400
Div 5													
10	5524	Aluminum Handrail	LF	200	\$6.00	\$1,200	\$35.00	\$7,000	\$2.90	\$580		\$0	\$8,780
11		Ladder	VF	20	\$50.00	\$1,000	\$150.00	\$3,000	\$15.00	\$300		\$0	\$4,300
12	5530	Aluminum Grating Landing	SF	32	\$10.00	\$320	\$45.00	\$1,440	\$10.00	\$320		\$0	\$2,080
13	5530	Aluminum Grating	SF	240	\$10.00	\$2,400	\$20.00	\$4,800		\$0		\$0	\$7,200
Div 6													
Div 7													
14		Membrane Roofing	SF	1500		\$0		\$0		\$0	\$5.00	\$7,500	\$7,500
15		Dampproofing - Walls	SF	2400		\$0		\$0		\$0	\$0.56	\$1,340	\$1,340
16		1" Rigid Insulation - Walls	SF	2400		\$0		\$0		\$0	\$1.07	\$2,570	\$2,570
17	7210	Walls - Core Fill Foam Insulation (12" CMU)	SF	2400		\$0		\$0		\$0	\$0.61	\$1,460	\$1,460
Div 8													
18	8120	Hollow Metal Doors, Hardware, and Frames - Single	EA	10	\$150.00	\$1,500	\$400.00	\$4,000		\$0		\$0	\$5,500
19	8120	Hollow Metal Doors, Hardware, and Frames - Double	EA	2	\$150.00	\$300	\$800.00	\$1,600		\$0		\$0	\$1,900
20		Windows	LS	1	\$3,000.00	\$3,000	\$8,000.00	\$8,000	\$1,000.00	\$1,000		\$0	\$12,000
21	8331	Roll Up Aluminum Door (10'x12')	EA	2	\$800.00	\$1,600	\$4,500.00	\$9,000	\$50.00	\$100		\$0	\$10,700
Div 9													
22	9900	Painting	LS	1		\$0		\$0		\$0	\$50,000.00	\$50,000	\$50,000
Div 10													
Div 11													
23		Screens	EA	4	\$3,500.00	\$14,000	\$200,000.00	\$800,000	\$500.00	\$2,000		\$0	\$816,000
24		Eductors	EA	20	\$200.00	\$4,000	\$2,500.00	\$50,000	\$50.00	\$1,000		\$0	\$55,000
25		Pumps (2 MGD, 50 Feet Static Head)	EA	2	\$3,500.00	\$7,000	\$35,000.00	\$70,000	\$1,000.00	\$2,000		\$0	\$79,000
Div 12													
Div 13													
Div 14													
26		Bridge Crane	LS	1	\$4,500.00	\$4,500	\$65,000.00	\$65,000	\$1,500.00	\$1,500		\$0	\$71,000
Div 15													
27	15062	Ductile Iron Pipe	LS	1	\$7,195.00	\$7,200	\$127,359.83	\$127,360	\$1,840.00	\$1,840	\$0.00	\$0	\$136,400
28		PVC Piping	LS	1	\$1,250.00	\$1,250	\$8,000.00	\$8,000	\$750.00	\$750		\$0	\$10,000
29		Valves	LS	1	\$10,000.00	\$10,000	\$100,000.00	\$100,000	\$2,000.00	\$2,000	\$0.00	\$0	\$112,000
30		HVAC and Plumbing	LS	1		\$0		\$0		\$0	\$42,000.00	\$42,000	\$42,000
Div 16													
31	16000	Electrical	LS	1		\$0		\$0		\$0	\$490,000.00	\$490,000	\$490,000
32		CCTV Allowance	LS	0		\$0		\$0		\$0		\$0	\$0
33		Ductbank	LF	3000		\$0		\$0		\$0	\$150.00	\$450,000	\$450,000
Div 17													
34	17000	Instrumentation	LS	1		\$0		\$0		\$0	\$160,000.00	\$160,000	\$160,000
		Contingency	LS	10%		\$50,000		\$179,000		\$37,000		\$195,000	\$461,000
		Subtotals				\$549,390		\$1,964,240		\$406,140		\$2,147,070	\$5,066,840

			Assumptions:	
Sales Tax @	7.0%	\$137,500	Assumes that EPD will allow withdrawal from this source	
Labor Burden @	30.0%	\$164,800	15 foot wide Asphalt access road with 10-foot high fence	
Bonds On Subs @	1.5%	\$32,200	Pump Station firm capacity is 2 MGD	
Subtotal		\$5,401,340	Pump Station has a 2 channel intake	
Fee @	7.0%	\$378,100	Pump Station footprint is approximately 100 feet by 29 feet	
Insurance & Bonds @	1.7%	\$98,300	Pump Station main building footprint is approximately 35 feet by 25 feet	
			Pump Station main building also houses the electrical room and is made of brick and block	
			A Transformer is being provided by the Utility Company at the access road entrance	
Estimated Construction Cost		\$5,877,740	Estimate DOES NOT include easements acquisitions, land acquisitions, withdrawal permits or mitigations required to build the pump station	

WATERSHED DAM ASSESSMENT - (7194-001)
LITTLE TALLAPOOSA RIVER 20
OPINION OF PROBABLE CONSTRUCTION COST ESTIMATE - CONCEPTUAL LEVEL
 02 - 12-inch Raw Water Line

02
 DECEMBER 2007

TABLE A-3

No.	Spec. Sect.	Description	Unit	Qty	Labor \$\$		Material \$\$		Equipment \$\$		Subcontractor \$\$		Total
					Unit	Total	Unit	Total	Unit	Total	Unit	Total	
02 - 12-inch Raw Water Line with Venturi Vault													
Div 1													
1	1000	General Conditions	LS	1		\$12,000		\$8,900		\$12,300		\$0	\$33,200
Div 2													
2	2125	Erosion and Sedimentation Control Maintenance - with Unit Bid	MTH			\$0		\$0		\$0		\$0	\$0
3		Dewatering	LS			\$0		\$0		\$0		\$0	\$0
4	2510	Asphalt Concrete Pavement - with Unit Bid	LS			\$0		\$0		\$0		\$0	\$0
5	2523	Concrete Sidewalk and Curbs - with Unit Bid	LS			\$0		\$0		\$0		\$0	\$0
Div 3													
6	3300	Miscellaneous Concrete (Venturi Vault)	LS	1	\$1,200.00	\$1,200	\$12,500.00	\$12,500	\$1,000.00	\$1,000	\$0.00	\$0	\$14,700
Div 4													
Div 5													
Div 6													
Div 7													
Div 8													
Div 9													
Div 10													
Div 11													
Div 12													
Div 13													
Div 14													
Div 15													
7		24" DIP	Depth	5	Depth of Cover		4						
8		12" Pipe Excavation - Earth (compacted volume)	CY	2667	\$0.75	\$2,000		\$0	\$3.00	\$8,000		\$0	\$10,000
9		12" Pipe Excavation - Trench Rock (compacted volume)	CY	889		\$0		\$0		\$0	\$35.00	\$31,111	\$31,111
10		Trench Box	LF	4800		\$0	\$1.00	\$4,800		\$0		\$0	\$4,800
11		12" DIP Pressure Class 250	LF	3600	\$2.67	\$9,598	\$22.93	\$82,559	\$2.50	\$9,000		\$0	\$101,156
12		12" Pipe Bedding (compacted volume)	CY	711	\$1.00	\$711	\$13.00	\$9,244	\$1.00	\$711		\$0	\$10,667
13		12" Pipe Backfill (compacted volume)	CY	2705	\$1.00	\$2,705		\$0	\$4.00	\$10,819		\$0	\$13,524
14		Import Backfill Materials (loose volume, assume 10% swell)	CY	42		\$0	\$13.00	\$546		\$0		\$0	\$546
15		Haul off Rock (assume 15% swell) - with Unit Bid	CY	1022		\$0		\$0		\$0	\$15.00	\$15,333	\$15,333
16		12" 90-degree Bend	EA	1	\$127.20	\$127	\$314.44	\$314	\$50.00	\$50		\$0	\$492
17		12" 45-degree Bend	EA	2	\$127.20	\$254	\$269.11	\$538	\$50.00	\$100		\$0	\$893
18		12" 22.5-degree Bend	EA	2	\$127.20	\$254	\$272.70	\$545	\$50.00	\$100		\$0	\$900
19		12" 11.25-degree Bend	EA	3	\$127.20	\$382	\$274.12	\$822	\$50.00	\$150		\$0	\$1,354
20		12" DIP Pressure Class 250 RJ	LF	1200	\$9.17	\$10,999	\$30.61	\$36,731	\$2.50	\$3,000		\$0	\$50,730
21													
22		Earthwork Calculations				\$0		\$0		\$0		\$0	\$0
23		Pipe Excavation - Total Compacted Volume	CY	3556		\$0		\$0		\$0		\$0	\$0
24		Rock - Total Compacted Volume (assume 25% of excavation)	CY	889		\$0		\$0		\$0	\$37.00	\$32,889	\$32,889
25		Pipe Bedding - Total Compacted Volume	CY	711		\$0		\$0		\$0		\$0	\$0
26		Pipe Backfill - Total Compacted Volume Needed	CY	2705		\$0		\$0		\$0		\$0	\$0
27		On-Site Backfill Material Available - Compacted Volume	CY	2667		\$0		\$0		\$0		\$0	\$0
28		Materials for Import - Compacted Volume	CY	38		\$0		\$0		\$0		\$0	\$0
29													
30		Air Release Valve and Manhole (3 each)	LS	1	\$2,200.00	\$2,200	\$26,400.00	\$26,400	\$1,800.00	\$1,800	\$0.00	\$0	\$30,400
31													
Div 16													
32	16000	Electrical	LS	1		\$0		\$0		\$0	\$21,000.00	\$21,000	\$21,000
Div 17													
33	17000	Venturi Meter	LS	1	\$1,000.00	\$1,000	\$4,500.00	\$4,500	\$500.00	\$500		\$0	\$6,000
34	17000	Instrumentation	LS	1		\$0		\$0		\$0	\$12,000.00	\$12,000	\$12,000
		Contingency	LS	0%		\$0		\$0		\$0		\$0	\$0
		Subtotals				\$43,430		\$188,400		\$47,530		\$112,333	\$391,694
					Assumptions:								
Sales Tax @					7.0%	\$13,200	Estimate DOES NOT include easements acquisitions, land acquisitions or mitigations required to build the pump station						
Labor Burden @					30.0%	\$13,000	Assumed 25% of the excavated material is rock						
Bonds On Subs @					1.5%	\$1,700							
Subtotal						\$419,594							
Fee @					7.0%	\$29,400							
Insurance & Bonds @					1.7%	\$7,600							
Estimated Construction Cost						\$456,594							

\$95 per LF

WATERSHED DAM ASSESSMENT - (7194-001)
LITTLE TALLAPOOSA RIVER 20
OPINION OF PROBABLE CONSTRUCTION COST - CONCEPTUAL LEVEL
 03 - Reservoir Inlet Structure

03
 DECEMBER 2007

TABLE A-4

No.	Spec. Sect.	Description	Unit	Qty	Labor \$\$		Material \$\$		Equipment \$\$		Subcontractor \$\$		Total
					Unit	Total	Unit	Total	Unit	Total	Unit	Total	
03 - Reservoir Inlet Structure													
		Div 1											
1	1000	General Conditions	LS	1		\$18,000		\$14,500		\$18,300		\$0	\$50,800
		Div 2											
2	2200	Earth Work	LS	1	\$5,000.00	\$5,000	\$2,639.00	\$2,640	\$4,926.00	\$4,930	\$31,300.00	\$31,300	\$43,870
		Div 3											
3	3250	Water Stop	LF	500	\$1.25	\$630	\$2.00	\$1,000		\$0		\$0	\$1,630
4	3300	Concrete	LS	1	\$82,952.00	\$82,950	\$159,839.00	\$159,840	\$26,200.00	\$26,200	\$0.00	\$0	\$268,990
		Div 4											
		Div 5											
7	5524	Aluminum Handrail	LF		\$6.00	\$0	\$35.00	\$0	\$2.90	\$0		\$0	\$0
8		Ladder	VF		\$50.00	\$0	\$150.00	\$0	\$15.00	\$0		\$0	\$0
9	5530	Aluminum Grating Landing	SF		\$10.00	\$0	\$45.00	\$0	\$10.00	\$0		\$0	\$0
10	5530	Aluminum Grating	SF		\$10.00	\$0	\$20.00	\$0		\$0		\$0	\$0
		Div 6											
		Div 7											
		Div 8											
		Div 9											
10	9900	Painting	LS			\$0		\$0		\$0		\$0	\$0
		Div 10											
		Div 11											
11		Sluice Gates and Operators	EA	2	\$2,500.00	\$5,000	\$25,000.00	\$50,000	\$1,000.00	\$2,000		\$0	\$57,000
		Div 12											
		Div 13											
		Div 14											
		Div 15											
12	15062	Ductile Iron Pipe	LS	1	\$1,000.00	\$1,000	\$8,500.00	\$8,500	\$500.00	\$500		\$0	\$10,000
		Div 16											
13	16000	Electrical	LS			\$0		\$0		\$0	\$70,000.00	\$0	\$0
		Div 17											
14	17000	Instrumentation	LS			\$0		\$0		\$0	\$25,000.00	\$0	\$0
		Contingency	LS	0%		\$0		\$0		\$0		\$0	\$0
		Subtotals				\$112,580		\$236,480		\$51,930		\$31,300	\$432,290
		Sales Tax @		7.0%		\$16,600							
		Labor Burden @		30.0%		\$33,800							
		Bonds On Subs @		1.5%		\$500							
		Subtotal				\$483,190							
		Fee @		7.0%		\$33,800							
		Insurance & Bonds @		1.7%		\$8,800							
		Estimated Construction Cost				\$525,790							

Table A-5

Little Tallapoosa River Dam No. 20**TOTAL PROJECT OPINION OF COST**

<u>Item . No.</u>	<u>Description of Work</u>	<u>Estimated Quantity</u>	<u>Unit</u>	<u>Unit Price</u>	<u>Amount</u>
1.	Mobilization and Demobilization	1	Job	<u>Lump Sum</u>	<u>\$507,535.68</u>
2.	Erosion & Sediment Control	1	Job	<u>Lump Sum</u>	<u>\$169,178.56</u>
3.	Control of Water	1	Job	<u>Lump Sum</u>	<u>\$253,767.84</u>
4.	Clearing	93	Ac	<u>2,500.00</u>	<u>\$232,500.00</u>
5.	Clearing & Grubbing	3	Ac	<u>\$5,000.00</u>	<u>\$15,000.00</u>
6.	Earth Fill	15,477	Cu-Yd	<u>\$4.00</u>	<u>\$61,908.00</u>
7.	Drain Fill	871	Cu-Yd	<u>\$75.00</u>	<u>\$65,325.00</u>
8.	Excavation, Common	3,974	Cu-Yd	<u>\$5.00</u>	<u>\$19,870.00</u>
9.	Riprap	5,051	Ton	<u>\$75.00</u>	<u>\$378,825.00</u>
10.	Permanent Turf Establishment	3	Ac	<u>\$2,000.00</u>	<u>\$6,000.00</u>
11.	Concrete, Class 4000 (reinforced)	8,826	Cu-Yd	<u>\$850.00</u>	<u>\$7,502,100.00</u>
12.	Concrete, Class 3000 (mass)	51	Cu-Yd	<u>\$400.00</u>	<u>\$20,400.00</u>
13.	30-Inch RCP	280	Feet	<u>\$400.00</u>	<u>\$112,000.00</u>
14.	Principal Spillway Riser	1	Unit	<u>\$45,000.00</u>	<u>\$45,000.00</u>
<u>Dam Construction Cost Estimate</u>					<u>\$9,389,410.08</u>
15.	12-Inch Pipeline	1	Lump Sum	<u>\$460,000.00</u>	<u>\$460,000.00</u>
16.	Cascading Structure	1	Lump Sum	<u>\$530,000.00</u>	<u>\$530,000.00</u>

17.	Pumping Station (Including Raw Water Pumps and Access Road)	1	Lump Sum	\$5,880,000.00	\$5,880,000.00
	Pump Station and Pipeline Cost Estimate				\$6,870,000.00
18.	Land Acquisition	276	Ac	\$20,000.00	\$5,520,000.00
19.	Easement Acquisition	3	Ac	\$12,000.00	\$36,000.00
20.	Building Acquisition	15	Structures	\$200,000	\$3,000,000.00
	Land Acquisition Cost Estimate				\$8,556,000.00
21.	Wetland	682	Credits	\$7,500.00	\$5,115,000.00
22.	Intermittent Stream	64,676	Credits	\$90.00	\$5,820,840.00
23.	Lower Perennial Stream	146,964	Credits	\$90.00	\$13,226,760.00
24.	Open Water	209	Credits	\$7,500.00	\$1,567,500.00
	Impacts and Overall Mitigation Cost Estimate				\$25,730,100.00
	<u>Construction, Land Acquisition, Mitigation Estimate</u>				\$50,545,510.08
	<u>Contingency at 25%</u>				\$12,636,377.52
	<u>Professional Services at 15%*</u>				\$7,581,826.51
	<u>Total Project Estimate</u>				\$70,763,714.11
	<u>Suggested Project Estimate</u>				\$71,000,000.00

*Professional services include but are not limited to engineering, construction management legal, appraisals, and environmental consulting.